

**MOSFETs Silicon 40V N-Channel MOS**
**■ Applications**

- Synchronus Rectification
- Industrial and Motor Drive
- DC/DC and AC/DC Converters
- Power Tools

**■ Features**

- High-Speed Switching
- Low  $R_{DS(ON)}$
- Good stability and uniformity with high EAS
- RoHS and Halogen-Free Compliant
- 100% UIS and RG Tested

**■ Product Summary**

$V_{DS}$	40	V
$I_D$	160	A
$R_{DS(ON)}, TYP@10V$	4	m $\Omega$
$Q_g$	105	nC

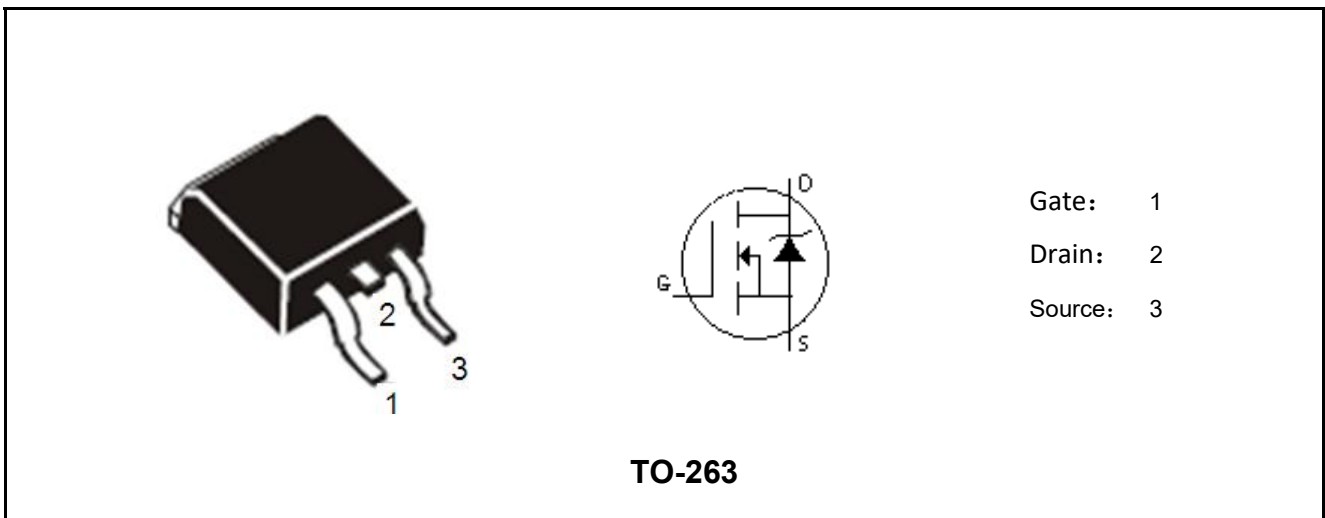

Marking	Package	Packaging	Min. package quantity
ML005R040PH	TO-263	Tube	1000
ML005R040PH	TO-263	Tape & Reel	800



**■ Absolute Maximum Ratings (Tc=25°C unless otherwise noted)**

Parameter	Symbol	Ratings	Unit
Drain-Source Voltage	$V_{DS}$	40	V
Gate-Source Voltage	$V_{GS}$	±20	V
Continuous Drain Current Tc=25°C (Note 1)	$I_D$	160	A
Continuous Drain Current Tc=100°C (Note 1)		105	A
Drain Current-Pulsed (Note 1)	$I_{DM}$	600	A
Total Dissipation	$P_D$	278	W
Junction Temperature	$T_j$	150	°C
Storage Temperature	$T_{stg}$	-55-150	°C
Single Pulse Avalanche Energy (Note 2)	$E_{AS}$	3000	mJ

Note: Using continuously under heavy loads (e.g. the application of high temperature/current/voltage and the significant change in temperature, etc.) may cause this product to decrease in the reliability significantly even if the operating conditions (i.e. operating temperature/current/voltage, etc.) are within the absolute maximum ratings.

**■ Thermal Characteristics**

Parameter	Symbol	Max	Unit
Maximum Junction-to-Case	$R_{\theta JC}$	0.45	°C/W
Maximum Junction-to-Ambient	$R_{\theta JA}$	60	°C/W

Note 1: Ensure that the channel temperature does not exceed 150°C.

Note 2:  $V_{DD}=30V$ ,  $T_{ch}=25^\circ C$  (initial),  $L=0.5mH$ ,  $R_g=25\Omega$ .

Note: This transistor is sensitive to electrostatic discharge and should be handled with care.



**■ Electrical Characteristics (Tc=25°C unless otherwise noted)**

Parameter	Symbol	Test Condition	Min	Typ	Max	Unit
<b>Static Parameters</b>						
Drain-Source Breakdown Voltage	$BV_{DSS}$	$V_{GS}=0V, I_D=250\mu A$	40	-	-	V
Drain-Source Leakage Current	$I_{DSS}$	$V_{DS}=40V, V_{GS}=0V$	-	-	1	$\mu A$
Gate-Body Leakage Current	$I_{GSS}$	$V_{GS}=\pm 20V, V_{DS}=0V$	-	-	$\pm 100$	nA
Gate Threshold Voltage	$V_{GS(TH)}$	$V_{GS}=V_{DS}, I_D=250\mu A$	2	2.8	4	V
Drain-Source On Resistance	$R_{DS(ON)}$	$V_{GS}=10V, I_D=20A$	-	4	5	m $\Omega$
		Tj=125°C	-	6.5	-	
<b>Dynamic Characteristics</b>						
Input Capacitance	$C_{iss}$	$V_{DS}=20V, V_{GS}=0V,$ $f=1.0MHz$	-	3500	-	pF
Output Capacitance	$C_{oss}$		-	2000	-	pF
Reverse Transfer Capacitance	$C_{rss}$		-	680	-	pF
Gate Resistance	$R_g$	$V_{DS}=0V, V_{GS}=0V,$ $f=1.0MHz$	-	1.3	-	$\Omega$
<b>Switching Parameters</b>						
Turn-On Delay Time	$t_{d(on)}$	$V_{DS}=20V, I_D=20A,$ $V_{GS}=10V, R_G=10\Omega$	-	25	-	ns
Turn-On Rise Time	$t_r$		-	210	-	ns
Turn-Off Delay Time	$t_{d(off)}$		-	45	-	ns
Turn-Off Fall Time	$t_f$		-	40	-	ns
Total Gate Charge	$Q_g$	$V_{DS}=20V, I_D=20A,$ $V_{GS}=10V$	-	105	-	nC
Gate-Source Charge	$Q_{gs}$		-	38	-	nC
Gate-Drain Charge	$Q_{gd}$		-	45	-	nC
<b>Source-Drain Characteristics</b>						
Diode Forward Voltage	$V_{sd}$	$V_{GS}=0V, I_S=10A$	-	0.8	1.2	V
Reverse Recovery Time	$t_{rr}$	$V_R=20V, I_F=20A,$ $di/dt=100A/\mu s$	-	80	-	ns
Reverse Recovery Charge	$Q_{rr}$		-	200	-	nC

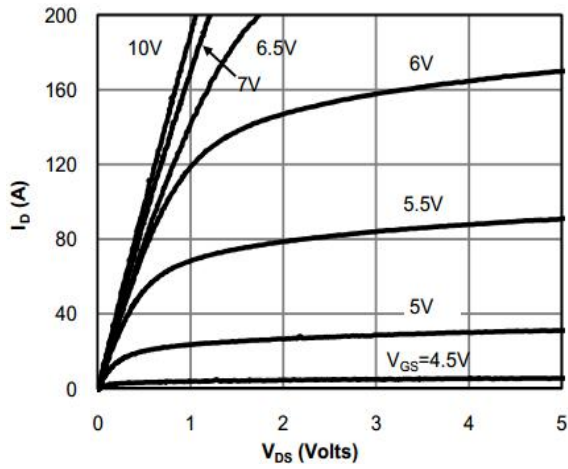
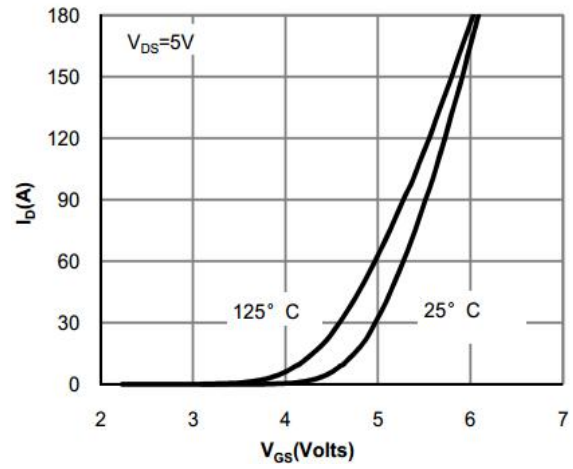
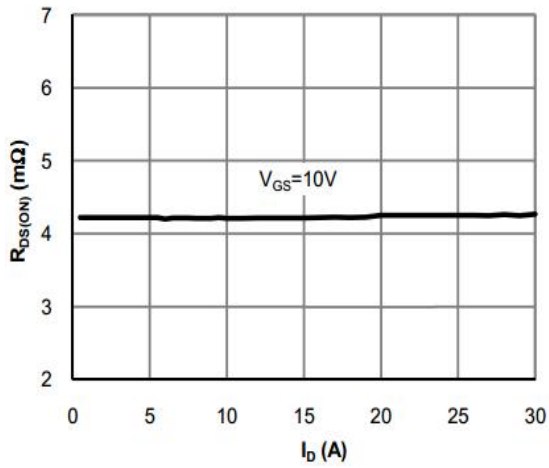
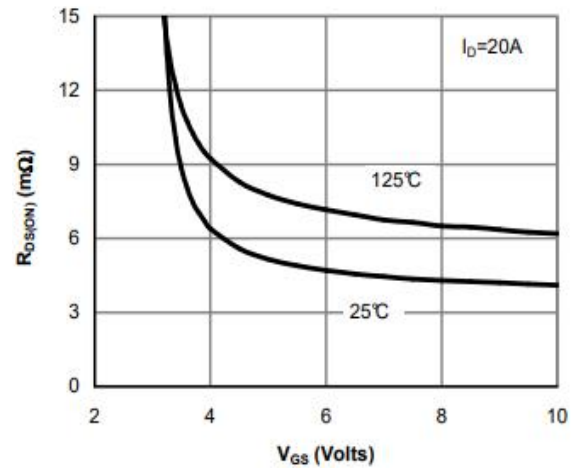
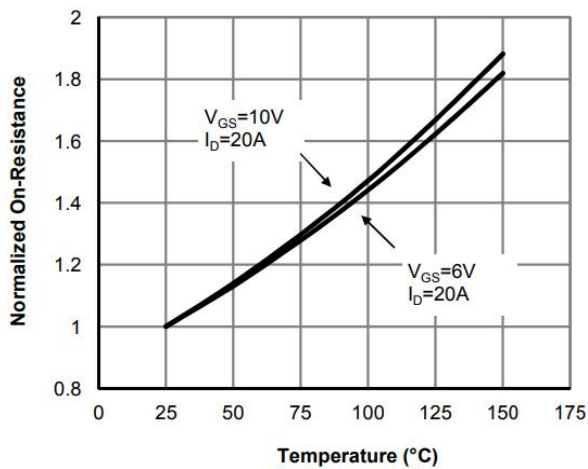
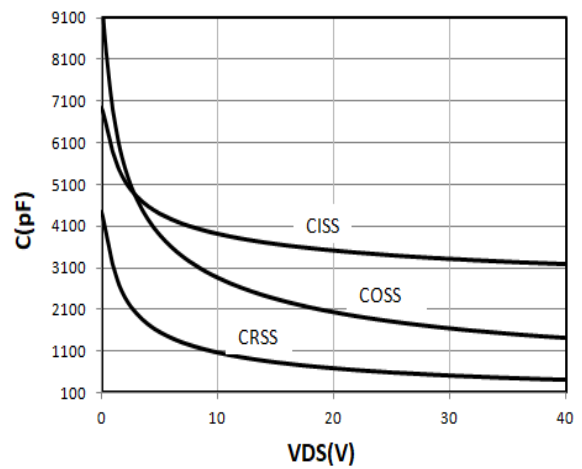

**■ Characteristics Curves**

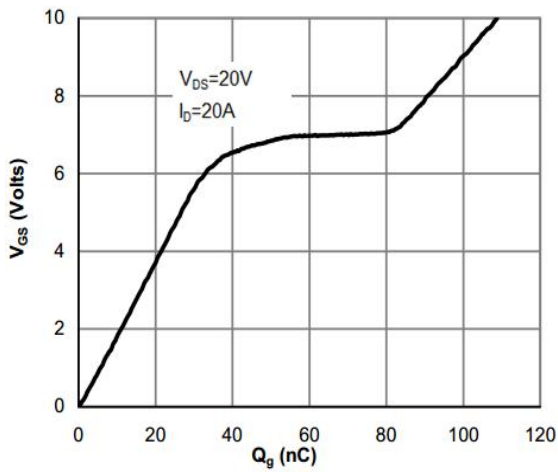
**Output Characteristics**

**Transfer Characteristics**

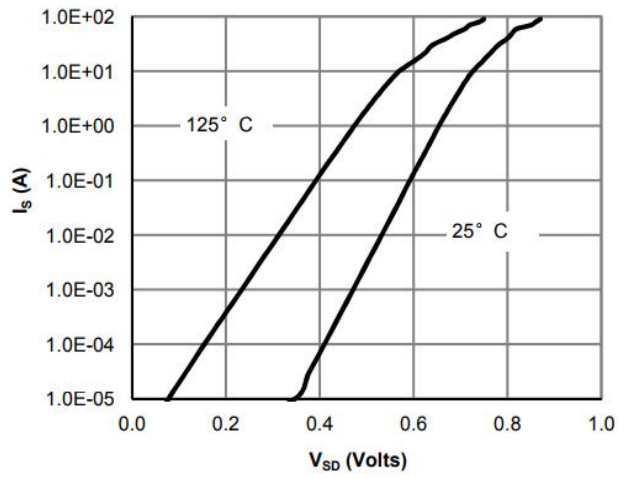
**On Resistance Vs Drain Current**

**On Resistance Vs Gate Source Voltage**

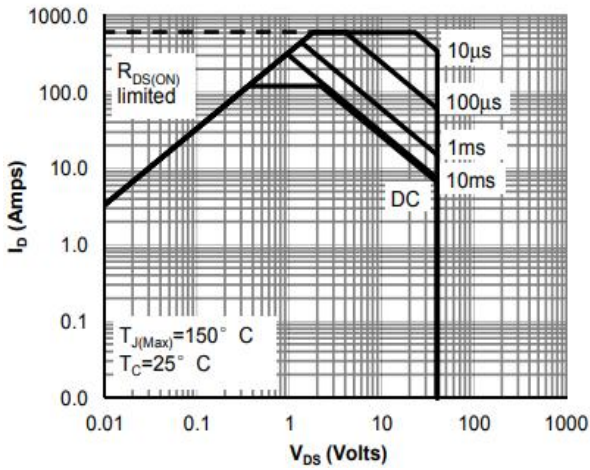
**Rdson-Junction Temperature**

**Capacitance**

Gate Charge Waveform



Source-Drain Diode Forward Voltage



Maximum Safe Operating Area

Note : The above characteristics curves are presented for reference only and not guaranteed by production test, unless otherwise noted.

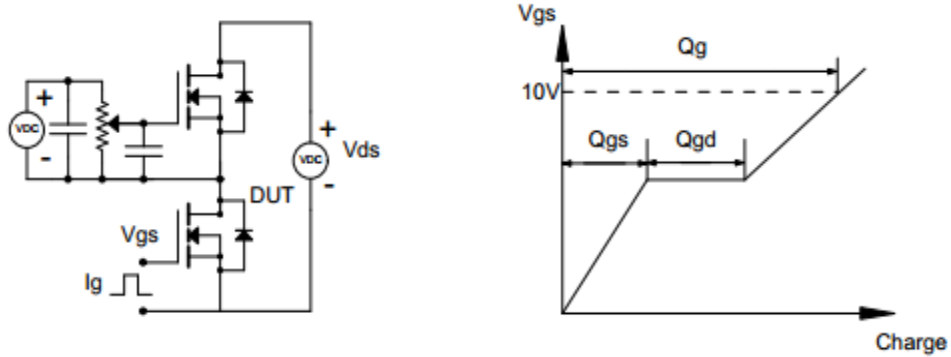
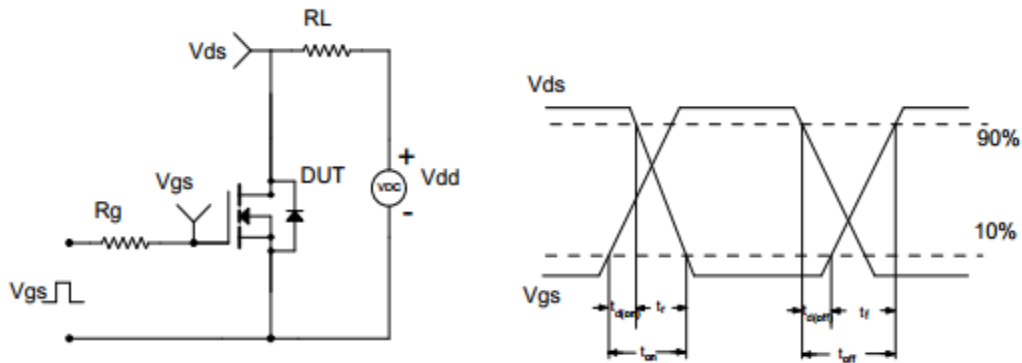
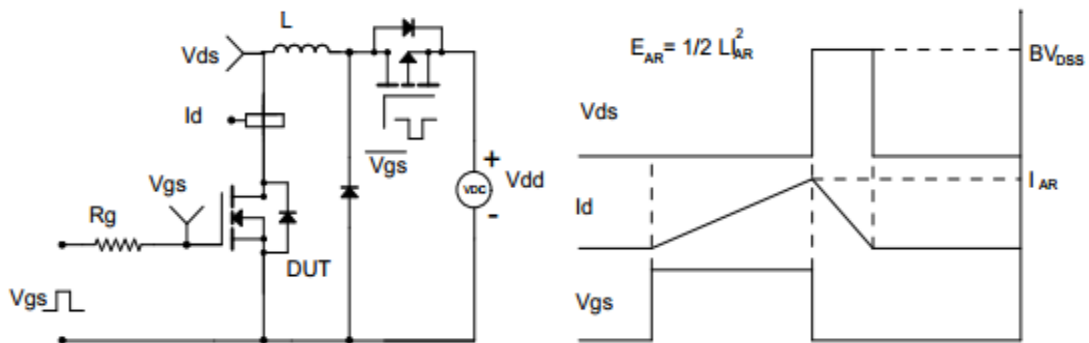

**■ Test Circuit & Waveform**
**Gate Charge Test Circuit & Waveform**

**Resistive Switching Test Circuit & Waveform**

**Unclamped Inductive Switching (UIS) Test Circuit & Waveform**

**■ TO-263 Package Dimensions**

Unit: mm

Symbol	Min	Nom	Max	Symbol	Min	Nom	Max
A	4.42		4.72	e1	2.44	2.54	2.64
B	1.22		1.4	e2	4.98		5.18
b	0.76		0.86	L1	14.7	15.1	15.5
b1	1.22		1.4	L2	2	2.3	2.6
b2	0.33		0.43	L3	1.5		2
C	1.22		1.35	K	-0.1		0.1
D	9.95		10.25	Y	8.51	8.61	8.71
E	8.99		9.29				

