

**MOSFETs Silicon 500V N-Channel MOS**
**■ Applications**

- Power factor correction (PFC)
- Switched mode power supplies(SMPS)
- Uninterruptible Power Supply (UPS)

**■ Features**

- Multi-Epi process SJ-FET
- Low  $R_{DS(ON)}$
- Ultra Low Gate Charge
- RoHS and Halogen-Free Compliant
- 100% UIS and RG Tested

**■ Product Summary**

$V_{DS} @ T_{j,max}$	550	V
$I_D$	18	A
$R_{DS(ON)}, Typ@10V$	0.18	$\Omega$
$Q_g$	20	nC

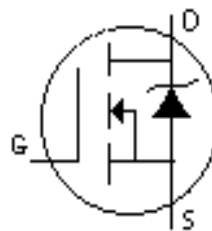
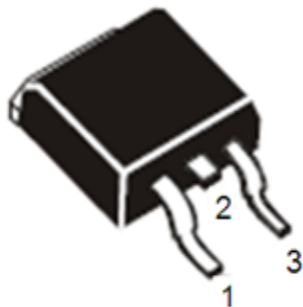

Gate: 1  
 Drain: 2  
 Source: 3

**TO-263**

Marking	Package	Packaging	Min. package quantity
ML240R50C	TO-263	Tube	1000
		Tape & Reel	800



**■ Absolute Maximum Ratings (Tc=25°C unless otherwise noted)**

Parameter	Symbol	Ratings	Unit
Drain-Source Voltage	$V_{DS}$	500	V
Gate-Source Voltage	$V_{GS}$	±30	V
Continuous Drain Current Tc=25°C (Note 1)	$I_D$	18	A
Continuous Drain Current Tc=100°C (Note 1)		11	
Drain Current-Pulsed (Note 1)	$I_{DM}$	43	A
Total Dissipation	$P_D$	125	W
Junction Temperature	$T_j$	150	°C
Storage Temperature	$T_{stg}$	-55-150	°C
Single Pulse Avalanche Energy (Note 2)	$E_{AS}$	284	mJ

Note: Using continuously under heavy loads (e.g. the application of high temperature/current/voltage and the significant change in temperature, etc.) may cause this product to decrease in the reliability significantly even if the operating conditions (i.e. operating temperature/current/voltage, etc.) are within the absolute maximum ratings.

**■ Thermal Characteristics**

Parameter	Symbol	Max	Unit
Maximum Junction-to-Case	$R_{\theta JC}$	1	°C/W
Maximum Junction-to-Ambient (Note 3)	$R_{\theta JA}$	60	°C/W

Note 1: Ensure that the channel temperature does not exceed 150°C.

Note 2:  $V_{DD}=50V$ ,  $T_{ch}=25^\circ C$ (initial),  $I_{AS}=18A$ ,  $R_g=25\Omega$ .

Note 3: The value of  $R_{\theta JA}$  is measured with the device mounted on 1in2 FR-4 board with 2oz. Copper, in a still air environment with  $T_A=25^\circ C$ . The value in any given application depends on the user's specific board design.

Note: This transistor is sensitive to electrostatic discharge and should be handled with care.



**■ Electrical Characteristics (Tc=25°C unless otherwise noted)**

Parameter	Symbol	Test Condition	Min	Typ	Max	Unit
<b>Static Parameters</b>						
Drain-Source Breakdown Voltage	BV <sub>DSS</sub>	V <sub>GS</sub> =0V, I <sub>D</sub> =250uA	500	-	-	V
		T <sub>j</sub> =150°C	550	-	-	
Drain-Source Leakage Current	I <sub>DSS</sub>	V <sub>DS</sub> =500V, V <sub>GS</sub> =0V	-	-	1	uA
Gate-Body Leakage Current	I <sub>GSS</sub>	V <sub>GS</sub> =±30V, V <sub>DS</sub> =0V	-	-	±100	nA
Gate Threshold Voltage	V <sub>GS(TH)</sub>	V <sub>GS</sub> =V <sub>DS</sub> , I <sub>D</sub> =250uA	2.5	3.5	4.5	V
Drain-Source On Resistance	R <sub>DS(ON)</sub>	V <sub>GS</sub> =10V, I <sub>D</sub> =9A	-	0.18	0.24	Ω
		T <sub>j</sub> =150°C	-	0.5	-	
<b>Dynamic Characteristics</b>						
Input Capacitance	C <sub>iss</sub>	V <sub>DS</sub> =25V, V <sub>GS</sub> =0V, f=1.0MHz	-	815	-	pF
Output Capacitance	C <sub>oss</sub>		-	350	-	pF
Reverse Transfer Capacitance	C <sub>rss</sub>		-	10	-	pF
Gate Resistance	R <sub>g</sub>	V <sub>DS</sub> =0V, V <sub>GS</sub> =0V, f=1.0MHz	-	3.8	-	Ω
<b>Switching Paramters</b>						
Turn-On Delay Time	t <sub>d(on)</sub>	V <sub>DS</sub> =400V, I <sub>D</sub> =9A, V <sub>GS</sub> =10V, R <sub>G</sub> =25Ω	-	13	-	ns
Turn-On Rise Time	t <sub>r</sub>		-	12	-	ns
Turn-Off Delay Time	t <sub>d(off)</sub>		-	100	-	ns
Turn-Off Fall Time	t <sub>f</sub>		-	12	-	ns
Total Gate Charge	Q <sub>g</sub>	V <sub>DS</sub> =400V, I <sub>D</sub> =9A, V <sub>GS</sub> =10V	-	20	-	nC
Gate-Source Charge	Q <sub>gs</sub>		-	5	-	nC
Gate-Drain Charge	Q <sub>gd</sub>		-	7.5	-	nC
<b>Source-Drain Characteristics</b>						
Max. Diode Forward Current	I <sub>S</sub>		-	-	18	A
Max. Pulsed Forward Current	I <sub>SM</sub>		-	-	43	A
Diode Forward Voltage	V <sub>sd</sub>	V <sub>GS</sub> =0V, I <sub>S</sub> =9A	-	0.9	1.5	V
Reverse Recovery Time	t <sub>rr</sub>	V <sub>R</sub> =400V, I <sub>F</sub> =9A, di/dt=100A/us	-	340	-	ns
Reverse Recovery Charge	Q <sub>rr</sub>		-	4.5	-	μC

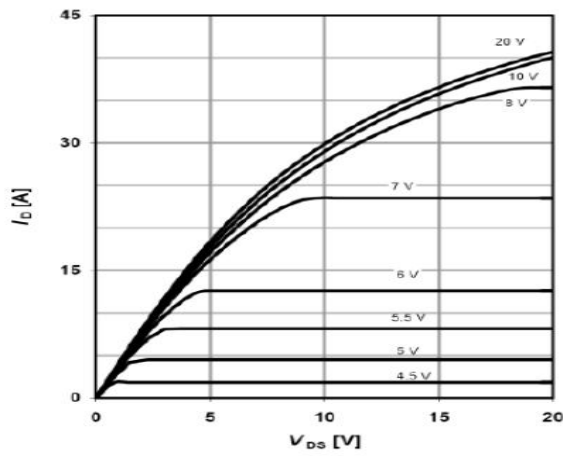
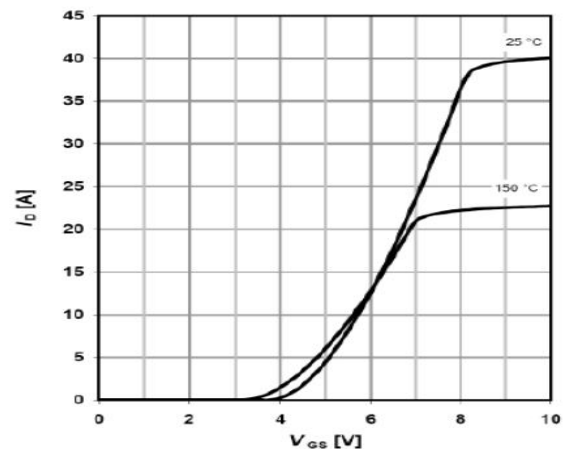
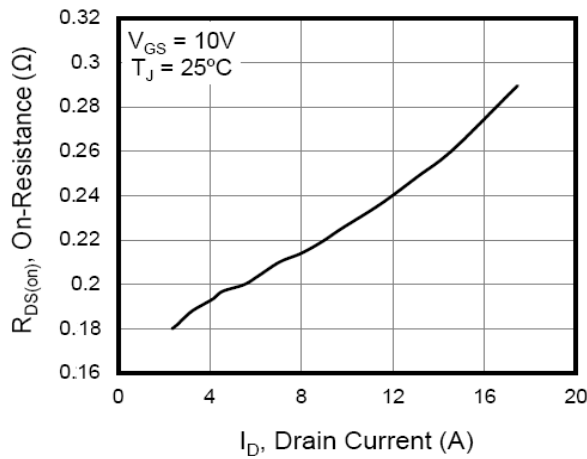
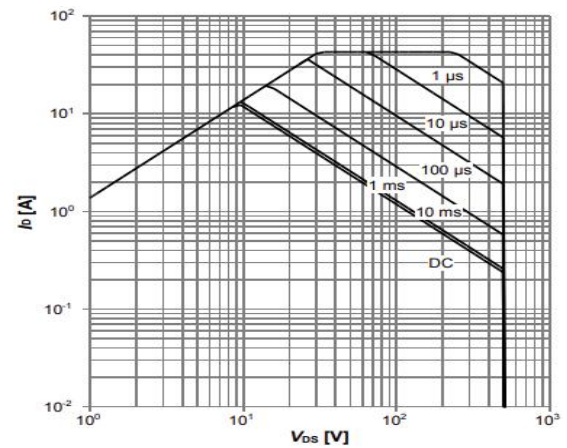
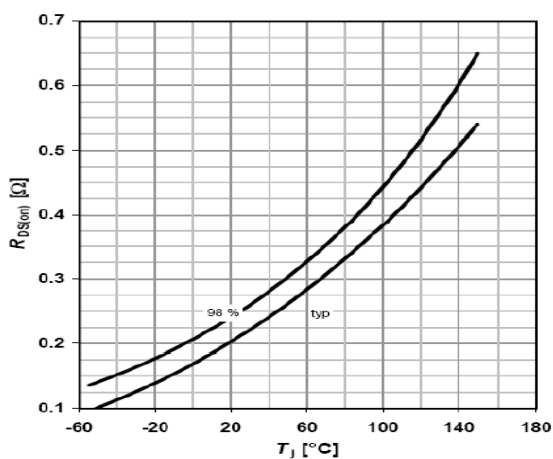
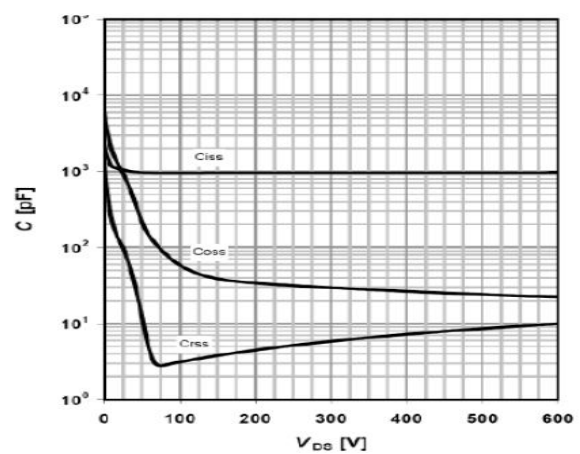

**■ Characteristics Curves**

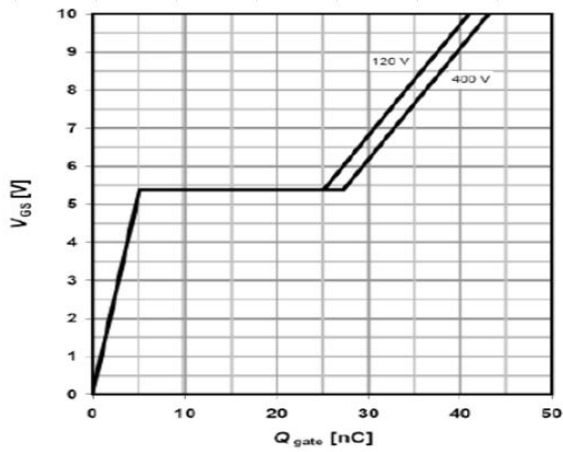
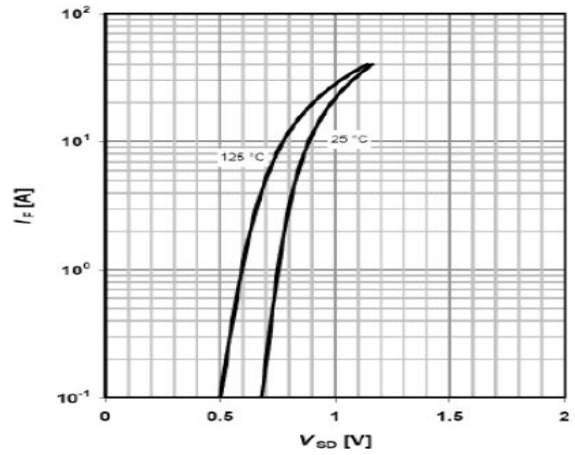
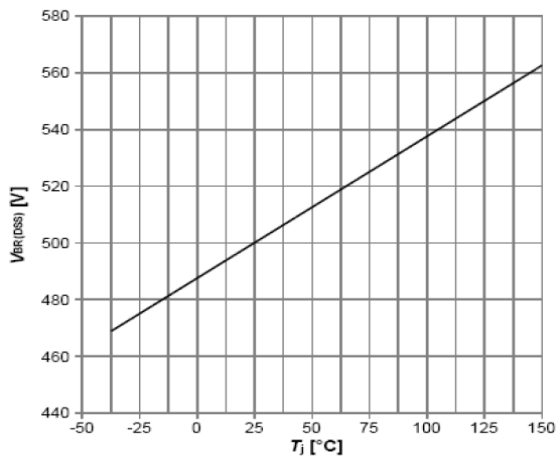
**Output Characteristics**

**Transfer Characteristics**

**On Resistance Vs Drain Current**

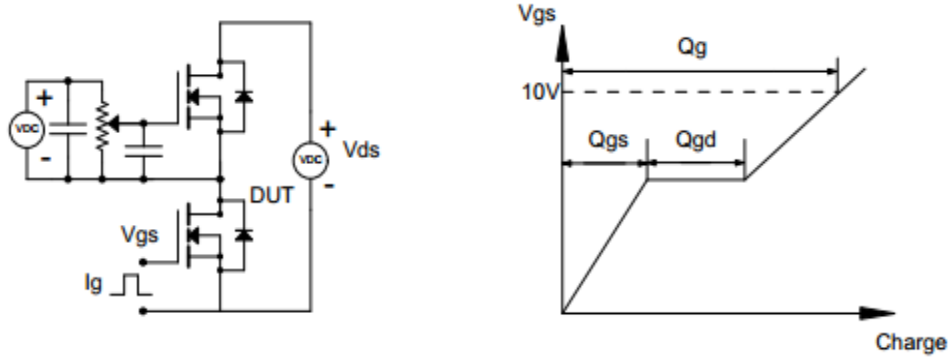
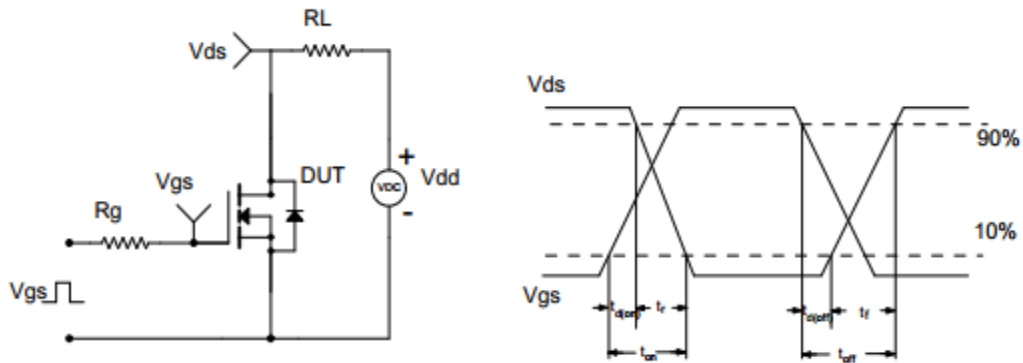
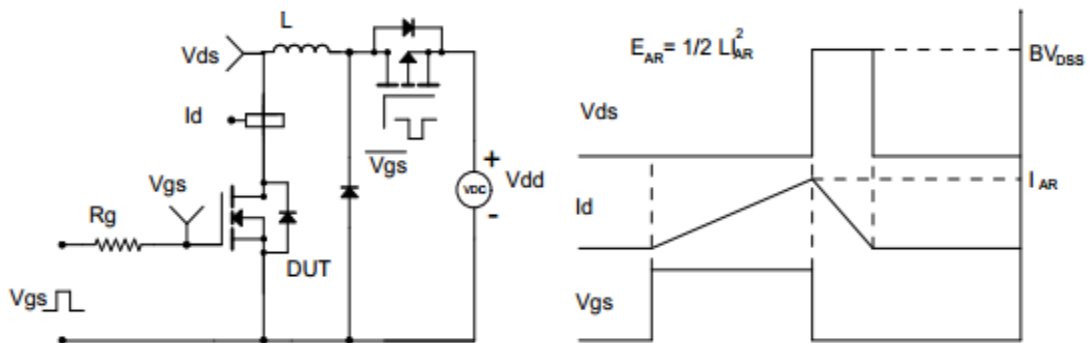
**Maximum Safe Operating Area**

**Rdson-Junction Temperature**

**Capacitance**



**Gate Charge Waveform**

**Source-Drain Diode Forward Voltage**

**Breakdown Voltage Vs Junction Temperature**

Note : The above characteristics curves are presented for reference only and not guaranteed by production test, unless otherwise noted.



**■ Test Circuit & Waveform**
**Gate Charge Test Circuit & Waveform**

**Resistive Switching Test Circuit & Waveform**

**Unclamped Inductive Switching (UIS) Test Circuit & Waveform**

**■ TO-263 Package Dimensions**

Unit: mm

Symbol	Min	Nom	Max	Symbol	Min	Nom	Max
A	4.42		4.72	E	8.99		9.29
B	1.22		1.4	e1	2.44	2.54	2.64
b	0.76		0.86	e2	4.98		5.18
b1	1.22		1.4	L1	14.7	15.1	15.5
b2	0.33		0.43	L2	2	2.3	2.6
C	1.22		1.35	L3	1.5		2
D	9.95		10.25	K	-0.1		0.1

