

MOSFETs Silicon 60V P-Channel MOS
■ Applications

- Synchronous Rectification
- Industrial and Motor Drive
- DC/DC and AC/DC Converters
- Power Tools

■ Features

- High-Speed Switching
- Low $R_{DS(ON)}$
- Capable of 4.5 V Gate Drive
- Good stability and uniformity with high EAS
- RoHS and Halogen-Free Compliant
- 100% UIS and RG Tested

■ Product Summary

V_{DS}	-60	V
I_D	-18	A
$R_{DS(ON), Typ@10V}$	80	m Ω
$R_{DS(ON), Typ@4.5V}$	95	m Ω
Q_g	17	nC

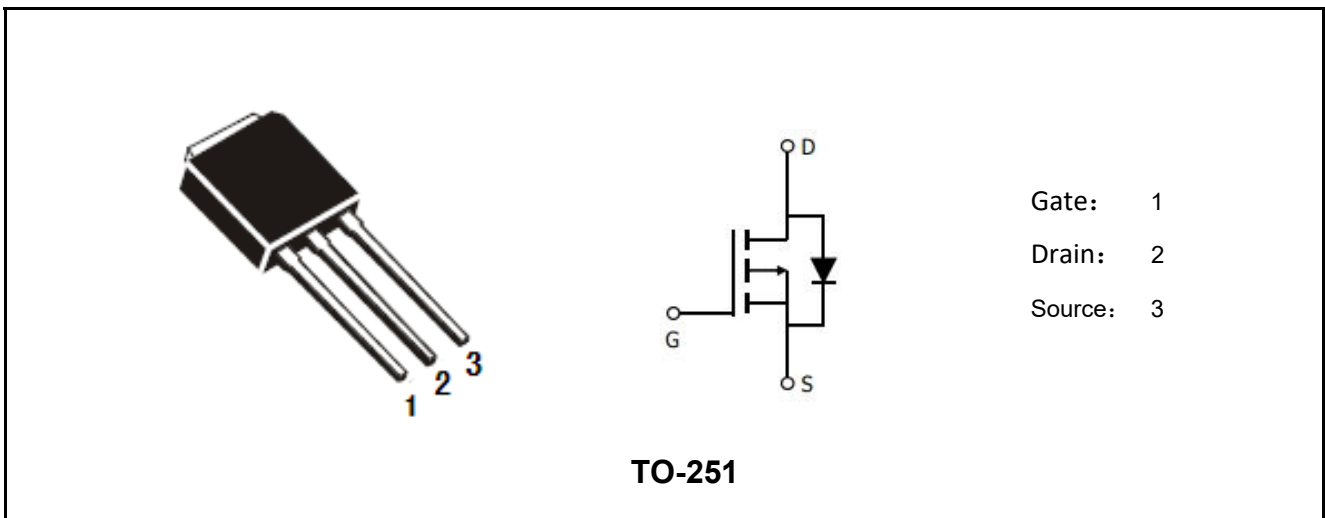

Marking	Package	Packaging	Min. package quantity
MJ090P060TL	TO-251	Tube	2400



■ Absolute Maximum Ratings (Tc=25°C unless otherwise noted)

Parameter	Symbol	Ratings	Unit
Drain-Source Voltage	V_{DS}	-60	V
Gate-Source Voltage	V_{GS}	±20	V
Continuous Drain Current Tc=25°C (Note 1)	I_D	-18	A
Continuous Drain Current Tc=100°C (Note 1)		-12	A
Drain Current-Pulsed (Note 1)	I_{DM}	-60	A
Total Dissipation	P_D	31	W
Junction Temperature	T_j	150	°C
Storage Temperature	T_{stg}	-55-150	°C
Single Pulse Avalanche Energy (Note 2)	E_{AS}	140	mJ

Note: Using continuously under heavy loads (e.g. the application of high temperature/current/voltage and the significant change in temperature, etc.) may cause this product to decrease in the reliability significantly even if the operating conditions (i.e. operating temperature/current/voltage, etc.) are within the absolute maximum ratings.

■ Thermal Characteristics

Parameter	Symbol	Max	Unit
Maximum Junction-to-Case	$R_{\theta JC}$	4	°C/W
Maximum Junction-to-Ambient	$R_{\theta JA}$	60	°C/W

Note 1: Ensure that the channel temperature does not exceed 150°C.

Note 2: $V_{DD}=50V$, $T_{ch}=25^\circ C$ (initial), $L=0.1mH$, $R_g=25\Omega$.

Note: This transistor is sensitive to electrostatic discharge and should be handled with care.



■ Electrical Characteristics (Tc=25°C unless otherwise noted)

Parameter	Symbol	Test Condition	Min	Typ	Max	Unit
Static Parameters						
Drain-Source Breakdown Voltage	BV_{DSS}	$V_{GS}=0V, I_D=-250\mu A$	-60	-	-	V
Drain-Source Leakage Current	I_{DSS}	$V_{DS}=-60V, V_{GS}=0V$	-	-	-1	μA
Gate-Body Leakage Current	I_{GSS}	$V_{GS}=\pm 20V, V_{DS}=0V$	-	-	± 100	nA
Gate Threshold Voltage	$V_{GS(TH)}$	$V_{GS}=V_{DS}, I_D=-250\mu A$	-1	-1.5	-2.2	V
Drain-Source On Resistance	$R_{DS(ON)}$	$V_{GS}=-4.5V, I_D=-8A$	-	95	120	m Ω
		Tj=125°C	-	142	-	
		$V_{GS}=-10V, I_D=-10A$	-	80	90	
		Tj=125°C	-	132	-	
Dynamic Characteristics						
Input Capacitance	C_{iss}	$V_{DS}=-35V, V_{GS}=0V,$ $f=1.0MHz$	-	930	1250	pF
Output Capacitance	C_{oss}		-	40	75	pF
Reverse Transfer Capacitance	C_{rss}		-	30	55	pF
Gate Resistance	R_g	$V_{DS}=0V, V_{GS}=0V,$ $f=1.0MHz$	-	5	8	Ω
Switching Paramters						
Turn-On Delay Time	$t_{d(on)}$	$V_{DS}=-30V, I_D=-10A,$ $V_{GS}=-10V, R_G=10\Omega$	-	7	-	ns
Turn-On Rise Time	t_r		-	18	-	ns
Turn-Off Delay Time	$t_{d(off)}$		-	32	-	ns
Turn-Off Fall Time	t_f		-	20	-	ns
Total Gate Charge	Q_g	$V_{DS}=-30V, I_D=-10A,$ $V_{GS}=-10V$	-	17	-	nC
Gate-Source Charge	Q_{gs}		-	3.5	-	nC
Gate-Drain Charge	Q_{gd}		-	3.2	-	nC
Source-Drain Characteristics						
Diode Forward Voltage	V_{sd}	$V_{GS}=0V, I_S=-10A$	-	0.94	1.2	V
Reverse Recovery Time	t_{rr}	$V_R=-30V, I_F=-10A,$ $di/dt=-100A/us$	-	35	-	ns
Reverse Recovery Charge	Q_{rr}		-	55	-	nC

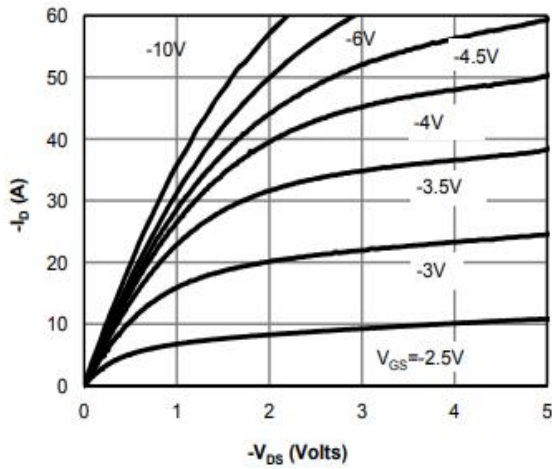
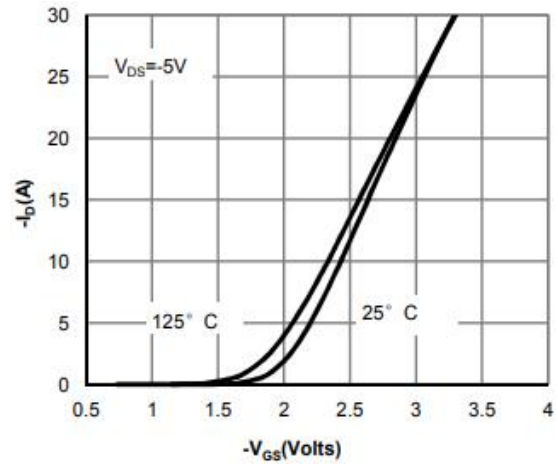
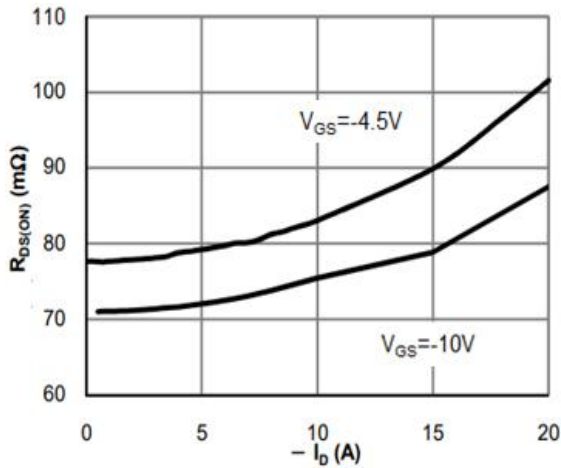
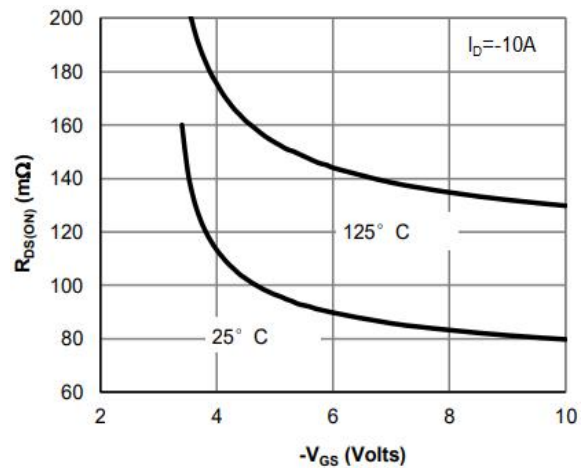
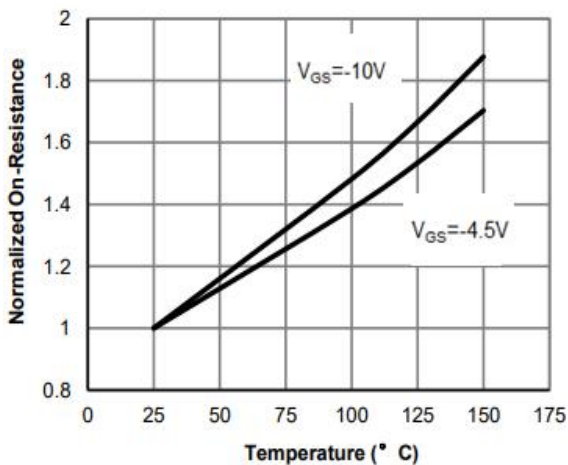
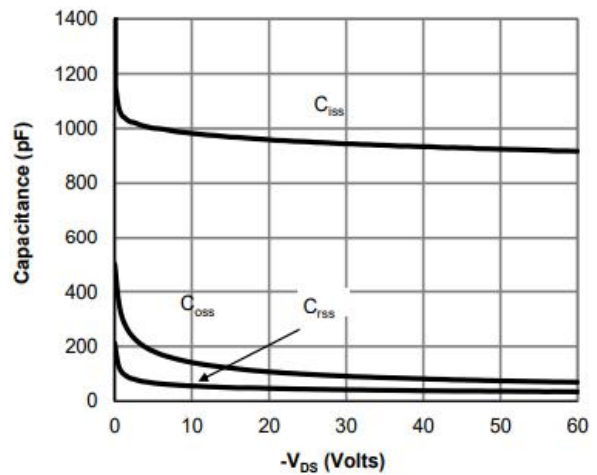

■ Characteristics Curves

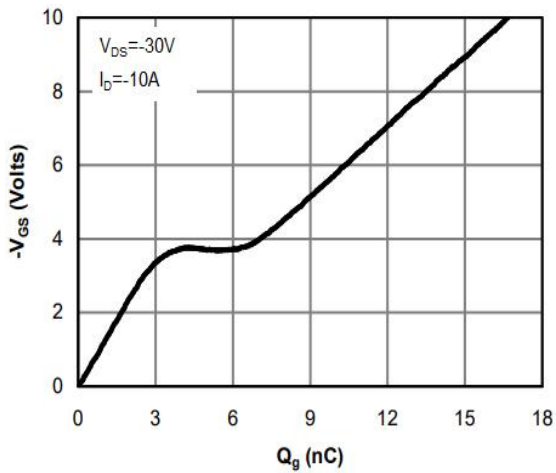
Output Characteristics

Transfer Characteristics

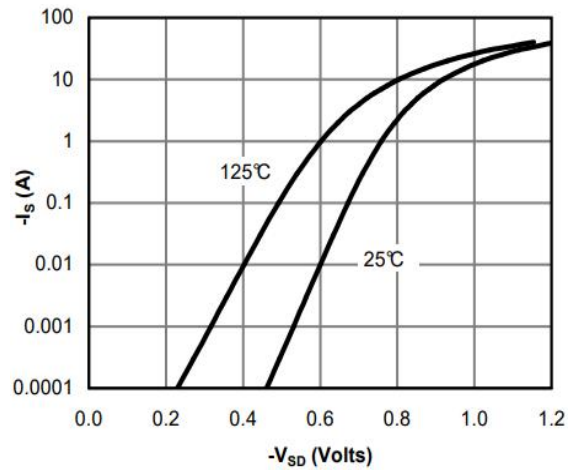
On Resistance Vs Drain Current

On Resistance Vs Gate Source Voltage

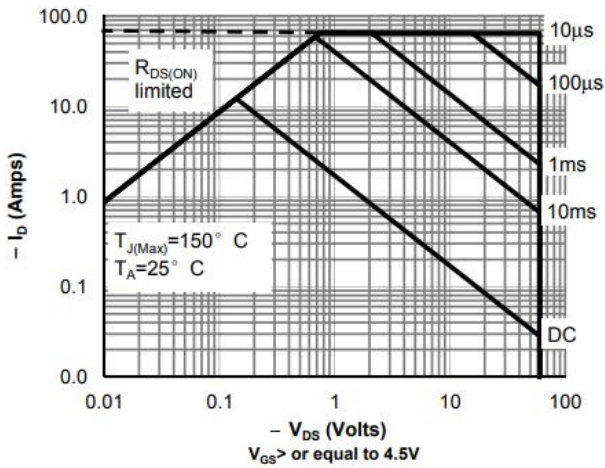
Rdson-JunctionTemperature

Capacitance

Gate Charge Waveform



Source-Drain Diode Forward Voltage



Maximum Safe Operating Area

Note : The above characteristics curves are presented for reference only and not guaranteed by production test, unless otherwise noted.

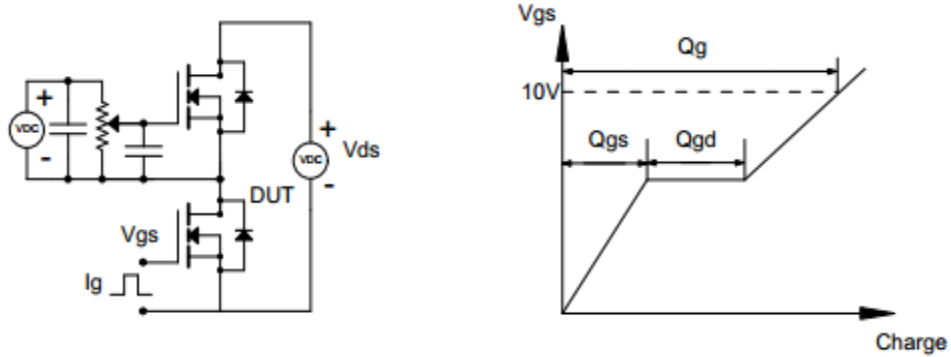
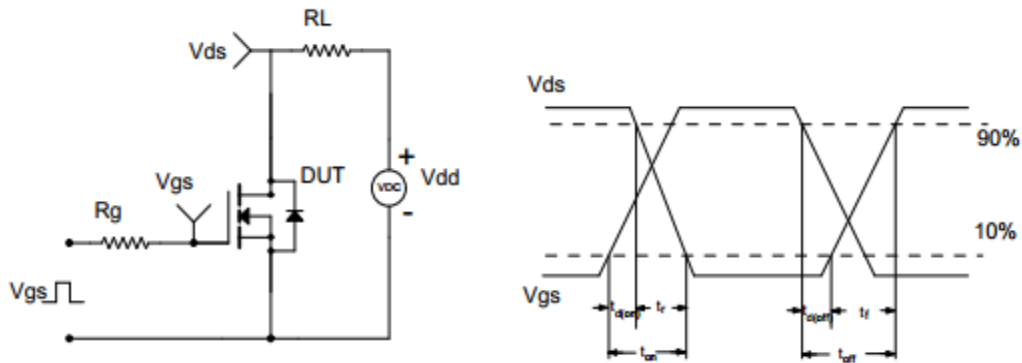
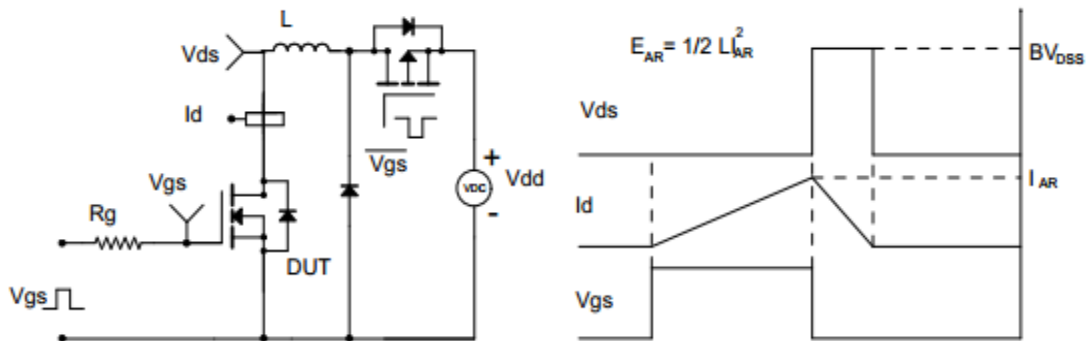

■ Test Circuit & Waveform
Gate Charge Test Circuit & Waveform

Resistive Switching Test Circuit & Waveform

Unclamped Inductive Switching (UIS) Test Circuit & Waveform

■ TO-251 Package Dimensions

Unit: mm

Symbol	Min	Nom	Max	Symbol	Min	Nom	Max
A	2.10		2.50	D1	5.10		5.50
A1	0.95		1.30	E	5.80		6.30
B	0.80		1.25	e	2.25	2.30	2.35
b	0.50		0.80	L	7.70		8.50
b1	0.70		0.90	L1	1.45		1.95
C	0.45		0.60	R		0.30	
C1	0.45		0.60				
D	6.35		6.75				

