

MOSFETs Silicon 500V N-Channel MOS
■ Applications

- Power factor correction (PFC)
- Switched mode power supplies(SMPS)
- Uninterruptible Power Supply (UPS)

■ Features

- Multi-Epi process SJ-FET
- Low $R_{DS(ON)}$
- Ultra Low Gate Charge
- RoHS and Halogen-Free Compliant
- 100% UIS and RG Tested

■ Product Summary

$V_{DS} @ T_{j,max}$	550	V
I_D	24	A
$R_{DS(ON), Typ @ 10V}$	0.12	Ω
Q_g	30	nC

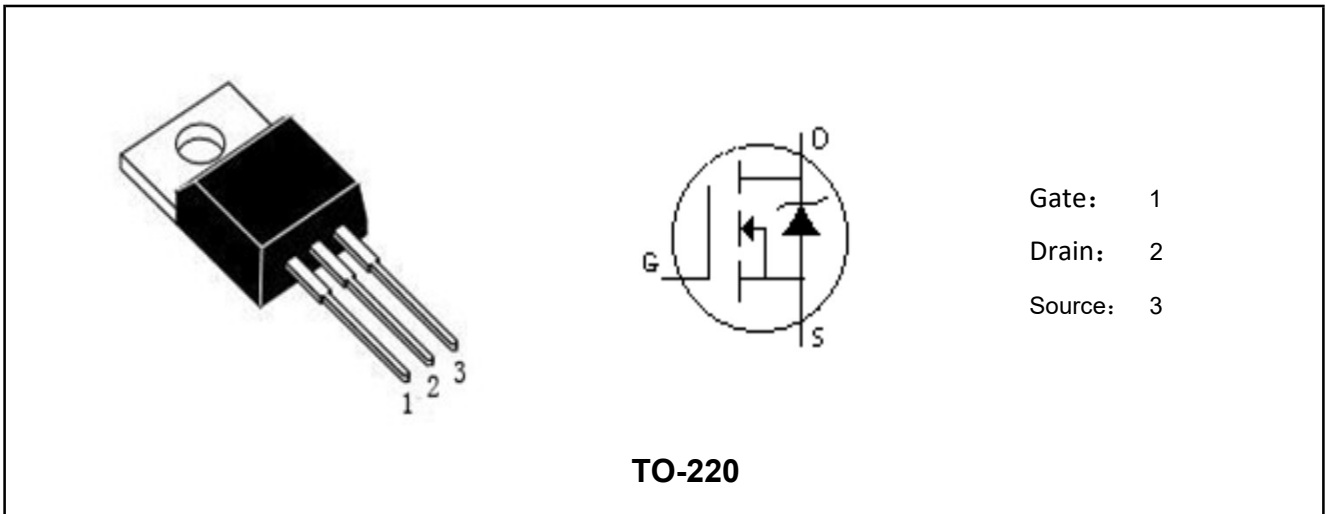

Marking	Package	Packaging	Min. package quantity
MC140R50C	TO-220	Tube	1000



■ Absolute Maximum Ratings (Tc=25°C unless otherwise noted)

Parameter	Symbol	Ratings	Unit
Drain-Source Voltage	V_{DS}	500	V
Gate-Source Voltage	V_{GS}	±30	V
Continuous Drain Current Tc=25°C (Note 1)	I_D	24	A
Continuous Drain Current Tc=100°C (Note 1)		15	
Drain Current-Pulsed (Note 1)	I_{DM}	70	A
Total Dissipation	P_D	150	W
Junction Temperature	T_j	150	°C
Storage Temperature	T_{stg}	-55-150	°C
Single Pulse Avalanche Energy (Note 2)	E_{AS}	485	mJ

Note: Using continuously under heavy loads (e.g. the application of high temperature/current/voltage and the significant change in temperature, etc.) may cause this product to decrease in the reliability significantly even if the operating conditions (i.e. operating temperature/current/voltage, etc.) are within the absolute maximum ratings.

■ Thermal Characteristics

Parameter	Symbol	Max	Unit
Maximum Junction-to-Case	$R_{\theta JC}$	0.83	°C/W
Maximum Junction-to-Ambient	$R_{\theta JA}$	60	°C/W

Note 1: Ensure that the channel temperature does not exceed 150°C.

Note 2: $V_{DD}=50V$, $T_{ch}=25^\circ C$ (initial), $I_{AS}=24A$, $R_g=25\Omega$.

Note: This transistor is sensitive to electrostatic discharge and should be handled with care.



■ Electrical Characteristics (Tc=25°C unless otherwise noted)

Parameter	Symbol	Test Condition	Min	Typ	Max	Unit
Static Parameters						
Drain-Source Breakdown Voltage	BV _{DSS}	V _{GS} =0V, I _D =250uA	500	-	-	V
		T _J =150°C	550	-	-	
Drain-Source Leakage Current	I _{DSS}	V _{DS} =500V, V _{GS} =0V	-	-	1	uA
Gate-Body Leakage Current	I _{GSS}	V _{GS} =±30V, V _{DS} =0V	-	-	±100	nA
Gate Threshold Voltage	V _{GS(TH)}	V _{GS} =V _{DS} , I _D =250uA	2.5	3.5	4.5	V
Drain-Source On Resistance	R _{DS(ON)}	V _{GS} =10V, I _D =12A	-	0.12	0.14	Ω
		T _J =150°C	-	0.3	-	
Dynamic Characteristics						
Input Capacitance	C _{iss}	V _{DS} =25V, V _{GS} =0V, f=1.0MHz	-	1330	-	pF
Output Capacitance	C _{oss}		-	520	-	pF
Reverse Transfer Capacitance	C _{rss}		-	15	-	pF
Gate Resistance	R _g	V _{DS} =0V, V _{GS} =0V, f=1.0MHz	-	4.8	-	Ω
Switching Paramters						
Turn-On Delay Time	t _{d(on)}	V _{DS} =400V, I _D =12A, V _{GS} =10V, R _G =20Ω	-	15	-	ns
Turn-On Rise Time	t _r		-	10	-	ns
Turn-Off Delay Time	t _{d(off)}		-	110	-	ns
Turn-Off Rise Time	t _f		-	9	-	ns
Total Gate Charge	Q _g	V _{DS} =400V, I _D =12A, V _{GS} =10V	-	30	-	nC
Gate-Source Charge	Q _{gs}		-	10	-	nC
Gate-Drain Charge	Q _{gd}		-	9	-	nC
Source-Drain Characteristics						
Max. Diode Forward Current	I _S		-	-	24	A
Max. Pulsed Forward Current	I _{SM}		-	-	70	A
Diode Forward Voltage	V _{sd}	V _{GS} =0V, I _S =12A	-	0.9	1.5	V
Reverse Recovery Time	t _{rr}	V _R =400V, I _F =12A, di/dt=100A/us	-	475	-	ns
Reverse Recovery Charge	Q _{rr}		-	5.8	-	μC

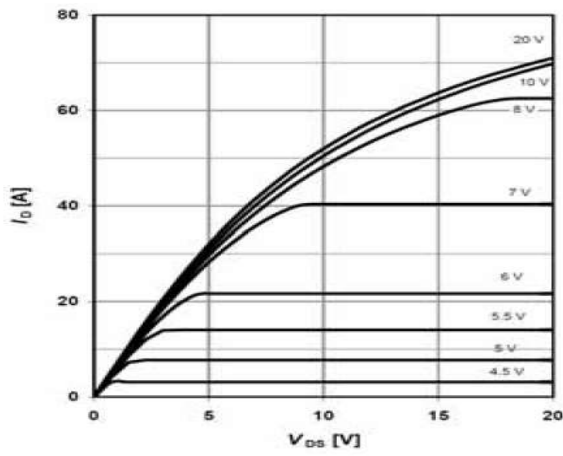
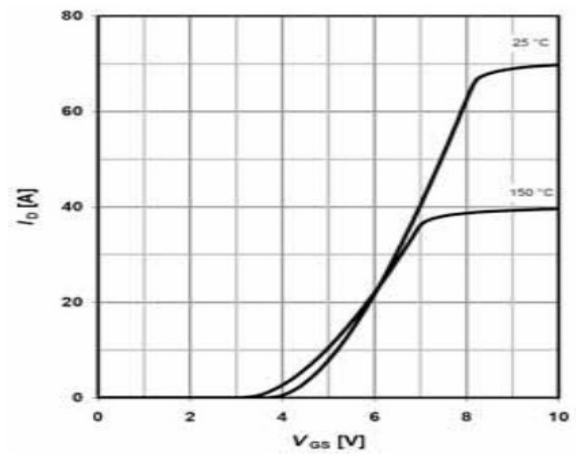
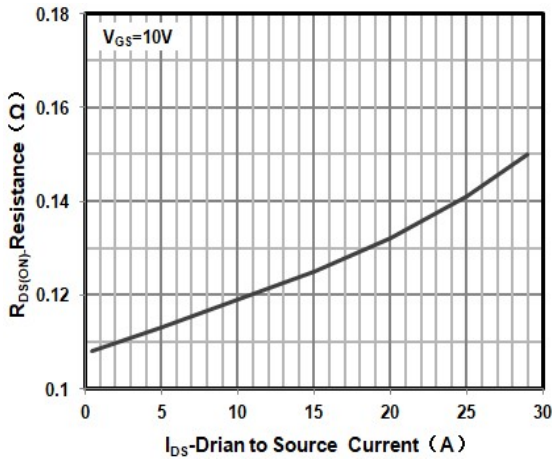
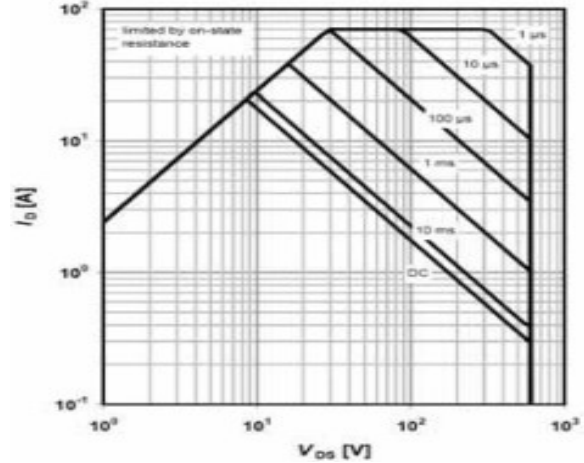
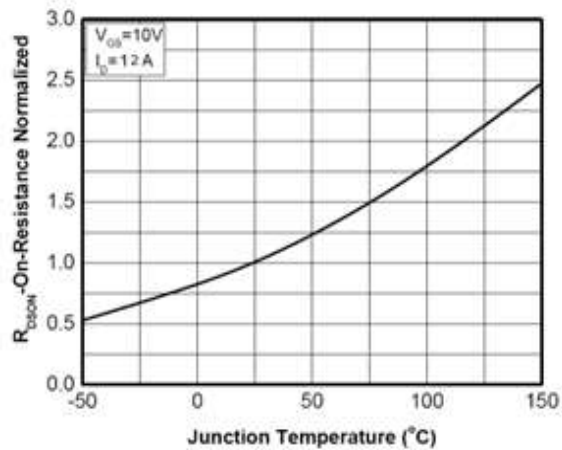
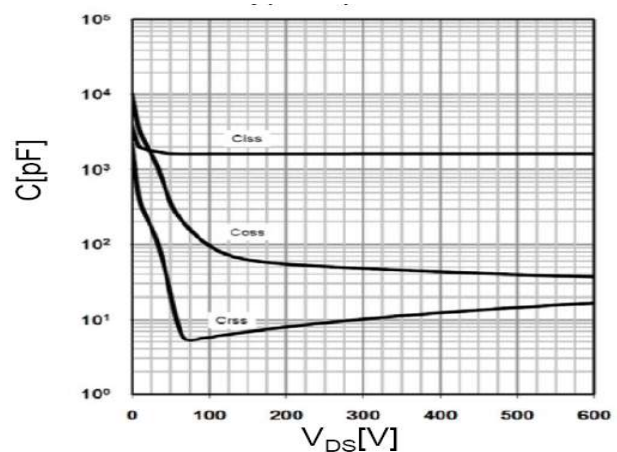

■ Characteristics Curves

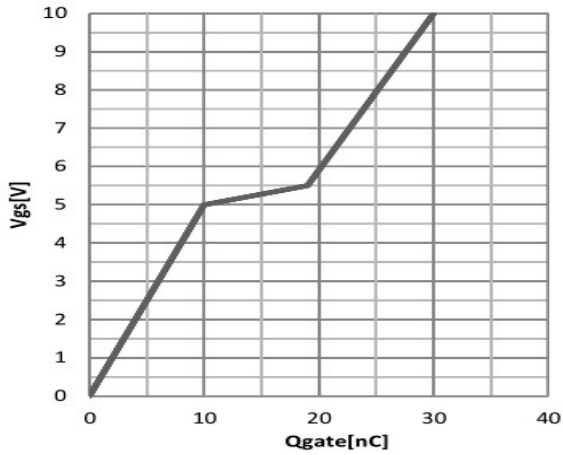
Output Characteristics

Transfer Characteristics

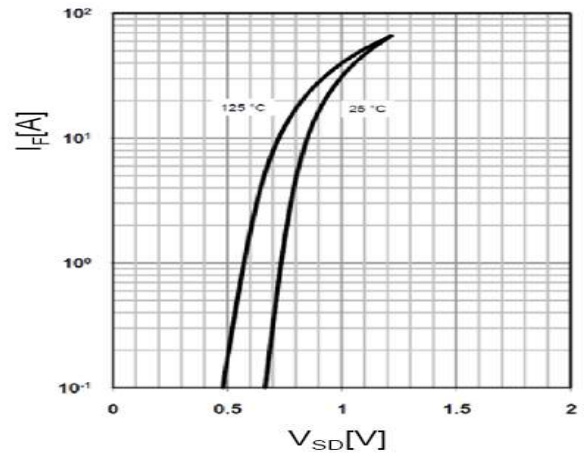
On Resistance Vs Drain Current

Maximum Safe Operating Area

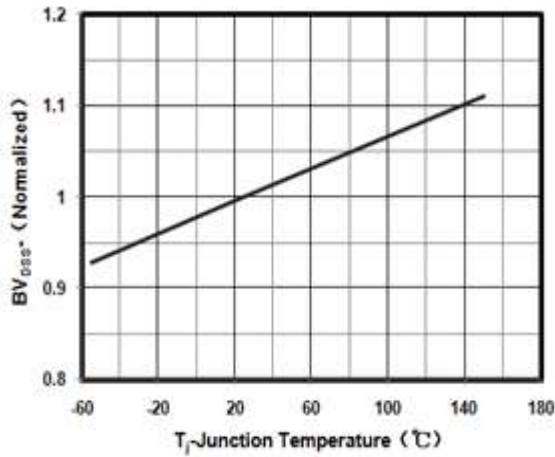
Rdson-Junction Temperature

Capacitance

Gate Charge Waveform



Source-Drain Diode Forward Voltage



Breakdown Voltage Vs Junction Temperature

Note : The above characteristics curves are presented for reference only and not guaranteed by production test, unless otherwise noted.

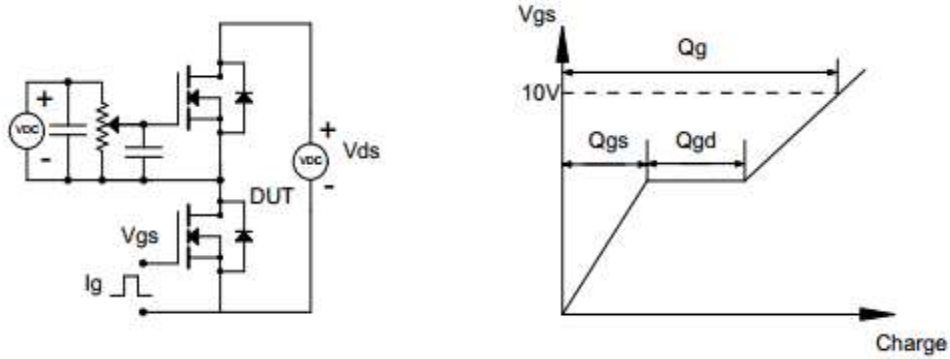
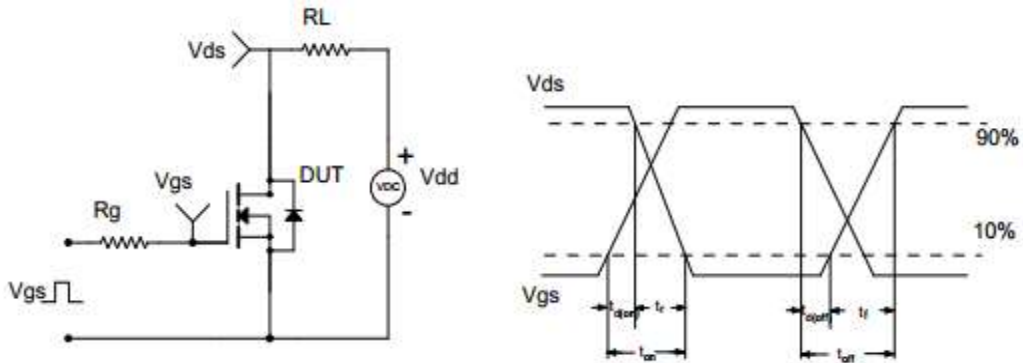
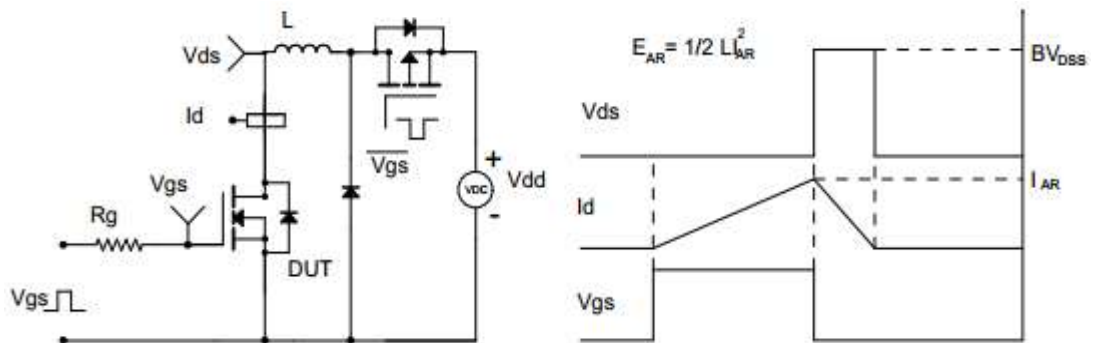

■ Test Circuit & Waveform
Gate Charge Test Circuit & Waveform

Resistive Switching Test Circuit & Waveform

Unclamped Inductive Switching (UIS) Test Circuit & Waveform

■ TO-220 Package Dimensions

Unit: mm

Symbol	Min	Nom	Max	Symbol	Min	Nom	Max
A	4.00		4.80	e	2.44	2.54	2.64
B	1.20		1.40	F	1.10		1.40
B1	1.00		1.40	L	12.50		14.50
b1	0.75		0.95	L1	3.00	3.50	4.00
c	0.40		0.55	ΦP	3.70	3.80	3.90
D	15.00		16.50	Q	2.50		3.00
D1	5.90		6.90	Q1	2.00		2.90
E	9.90		10.70	Y	8.02	8.12	8.22

