

MOSFETs Silicon 100V P-Channel MOS
■ Applications

- Synchronous Rectification
- Industrial and Motor Drive
- DC/DC and AC/DC Converters
- Power Tools

■ Features

- High-Speed Switching
- Low gate charge
- low reverse transmission capacitance
- Improved dv/dt capability
- RoHS and Halogen-Free Compliant
- 100% UIS and RG Tested

■ Product Summary

V_{DS}	-100	V
I_D	-12	A
$R_{DS(ON)}, Typ@10V$	160	m Ω
$R_{DS(ON)}, Typ@4.5V$	176	m Ω
Q_g	25	nC

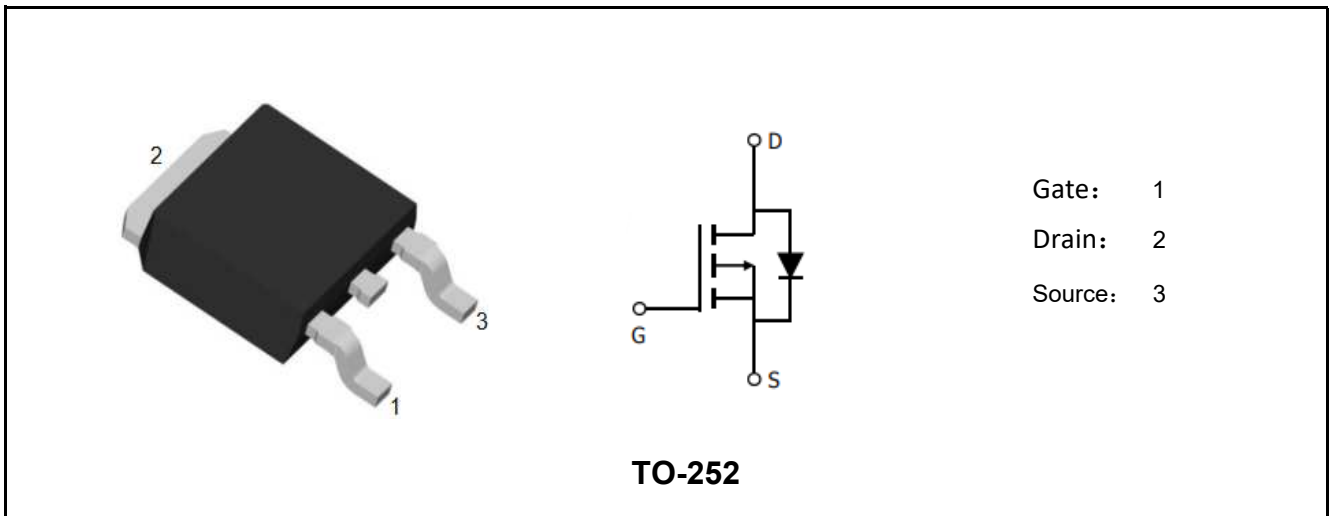

Marking	Package	Packaging	Min. package quantity
MK200P100TL	TO-252	Tape & Reel	3000



■ Absolute Maximum Ratings (Tc=25°C unless otherwise noted)

Parameter	Symbol	Ratings	Unit
Drain-Source Voltage	V_{DS}	-100	V
Gate-Source Voltage	V_{GS}	±20	V
Continuous Drain Current Tc=25°C (Note 1)	I_D	-12	A
Continuous Drain Current Tc=100°C (Note 1)		-7.5	A
Drain Current-Pulsed (Note 1)	I_{DM}	-48	A
Total Dissipation	P_D	45	W
Junction Temperature	T_J	150	°C
Storage Temperature	T_{stg}	-55-150	°C
Single Pulse Avalanche Energy (Note 2)	E_{AS}	28	mJ

Note: Using continuously under heavy loads (e.g. the application of high temperature/current/voltage and the significant change in temperature, etc.) may cause this product to decrease in the reliability significantly even if the operating conditions (i.e. operating temperature/current/voltage, etc.) are within the absolute maximum ratings.

■ Thermal Characteristics

Parameter	Symbol	Max	Unit
Maximum Junction-to-Case	$R_{\theta JC}$	2.75	°C/W
Maximum Junction-to-Ambient (Note 3)	$R_{\theta JA}$	60	°C/W

Note 1: Ensure that the channel temperature does not exceed 150°C.

Note 2: $V_{DD} = -50V$, $T_{ch} = 25^\circ C$ (initial), $L = 0.5mH$, $R_g = 25\Omega$.

Note 3: The value of $R_{\theta JA}$ is measured with the device mounted on 1in2 FR-4 board with 2oz. Copper, in a still air environment with $T_A = 25^\circ C$. The value in any given application depends on the user's specific board design.

Note: This transistor is sensitive to electrostatic discharge and should be handled with care.



■ Electrical Characteristics (Tc=25°C unless otherwise noted)

Parameter	Symbol	Test Condition	Min	Typ	Max	Unit
Static Parameters						
Drain-Source Breakdown Voltage	BV_{DSS}	$V_{GS}=0V, I_D=-250\mu A$	-100	-	-	V
Drain-Source Leakage Current	I_{DSS}	$V_{DS}=-100V, V_{GS}=0V$	-	-	-1	μA
Gate-Body Leakage Current	I_{GSS}	$V_{GS}=\pm 20V, V_{DS}=0V$	-	-	± 100	nA
Gate Threshold Voltage	$V_{GS(TH)}$	$V_{GS}=V_{DS}, I_D=-250\mu A$	-1.5	-2	-2.5	V
Drain-Source On Resistance	$R_{DS(ON)}$	$V_{GS}=-4.5V, I_D=-7.5A$	-	176	220	m Ω
		Tj=125°C	-	270	-	
		$V_{GS}=-10V, I_D=-7.5A$	-	160	200	
		Tj=125°C	-	255	-	
Dynamic Characteristics						
Input Capacitance	C_{iss}	$V_{DS}=-25V, V_{GS}=0V,$ $f=1.0MHz$	-	1330	-	pF
Output Capacitance	C_{oss}		-	60	-	pF
Reverse Transfer Capacitance	C_{rss}		-	45	-	pF
Switching Parameters						
Turn-On Delay Time	$t_{d(on)}$	$V_{DS}=-50V, I_D=-10A,$ $V_{GS}=-10V, R_G=5\Omega$	-	9	-	ns
Turn-On Rise Time	t_r		-	35	-	ns
Turn-Off Delay Time	$t_{d(off)}$		-	80	-	ns
Turn-Off Fall Time	t_f		-	50	-	ns
Total Gate Charge	Q_g	$V_{DS}=-50V, I_D=-10A,$ $V_{GS}=-10V$	-	25	-	nC
Gate-Source Charge	Q_{gs}		-	4	-	nC
Gate-Drain Charge	Q_{gd}		-	5	-	nC
Source-Drain Characteristics						
Diode Forward Voltage	V_{sd}	$V_{GS}=0V, I_S=-10A$	-	-0.8	-1.2	V
Reverse Recovery Time	t_{rr}	$V_R=-50V, I_F=-10A,$ $di/dt=-100A/\mu s$	-	35	-	ns
Reverse Recovery Charge	Q_{rr}		-	20	-	nC

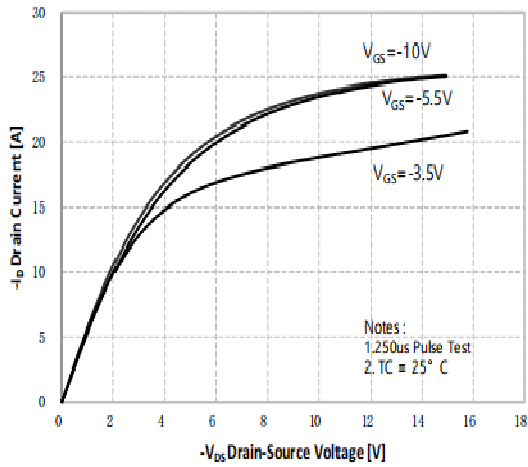
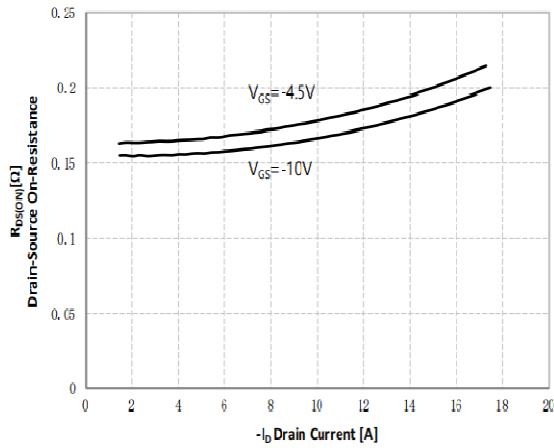
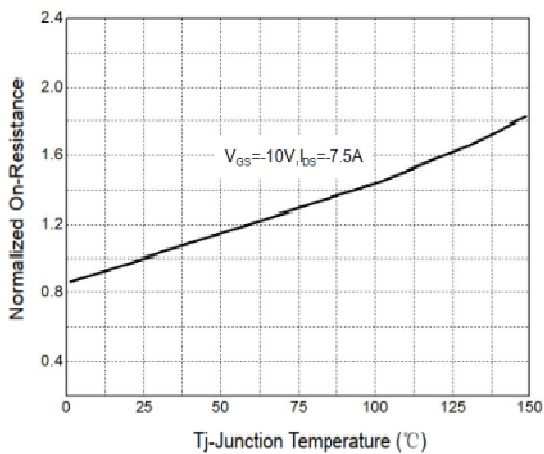
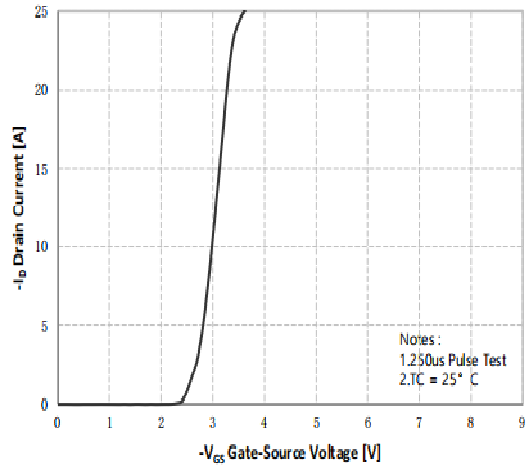
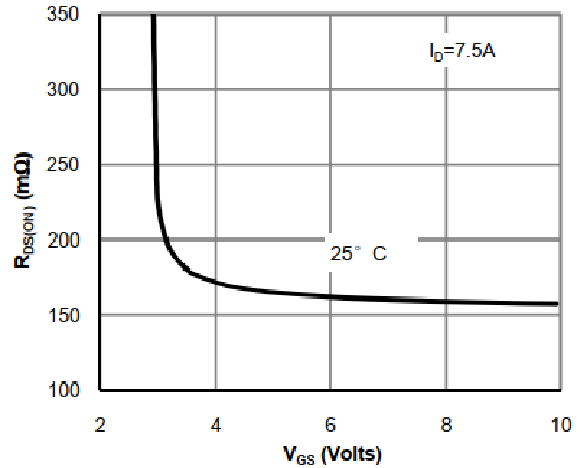
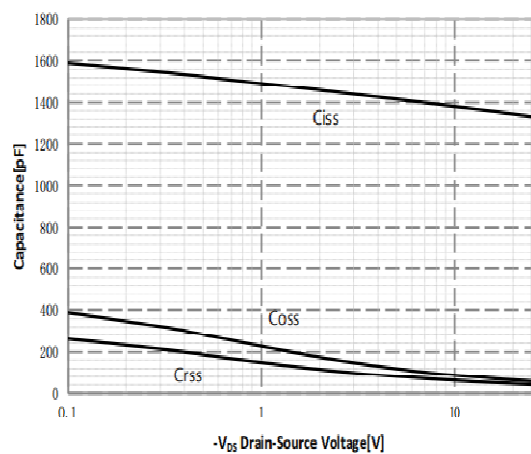

Characteristics Curves

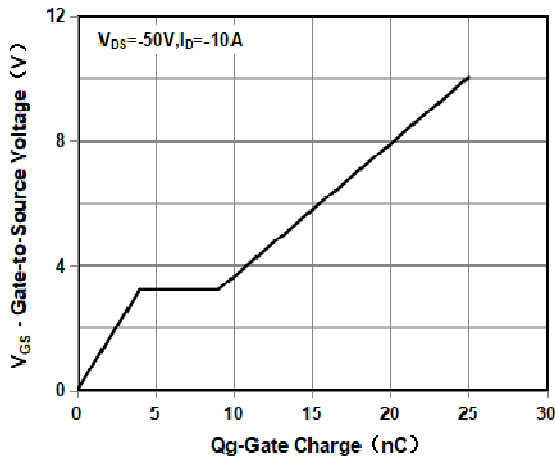
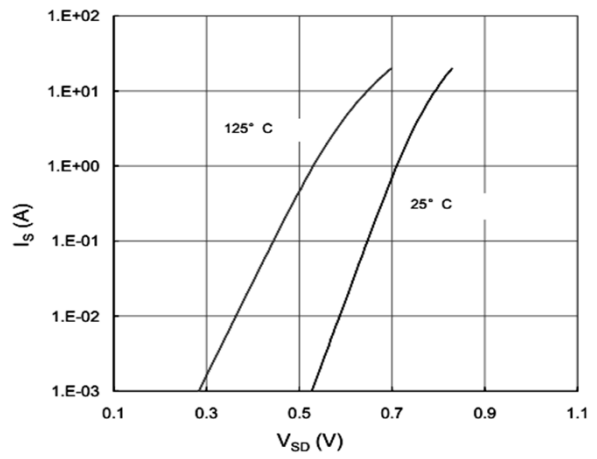
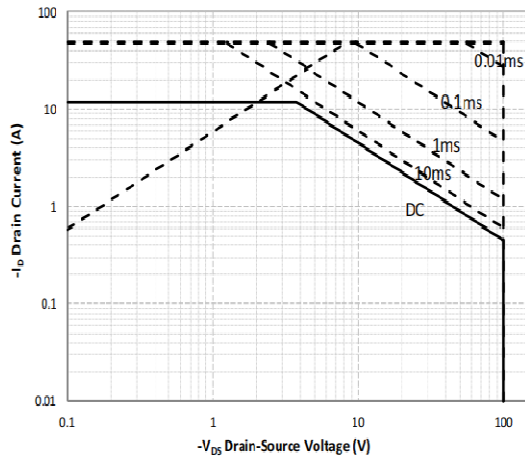
Output Characteristics

On Resistance Vs Drain Current

Rdson-JunctionTemperature

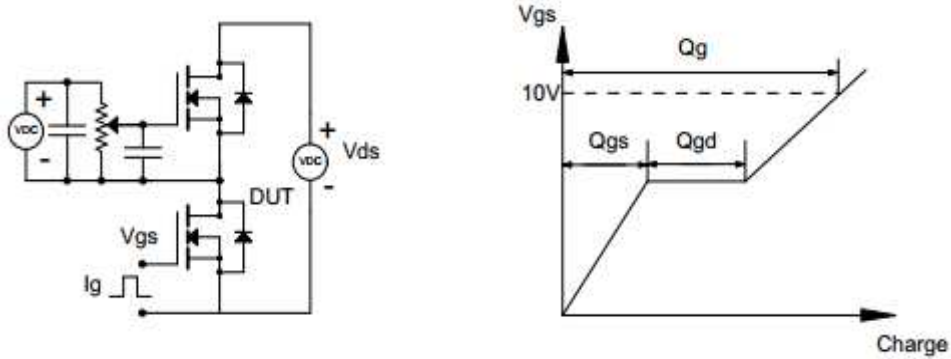
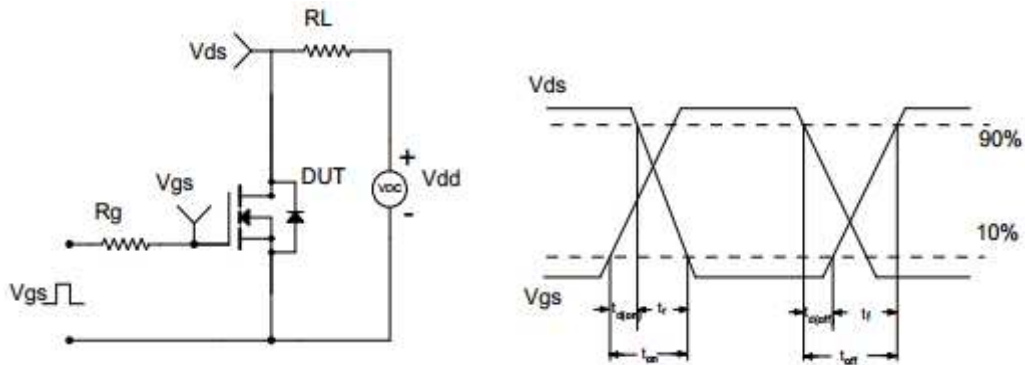
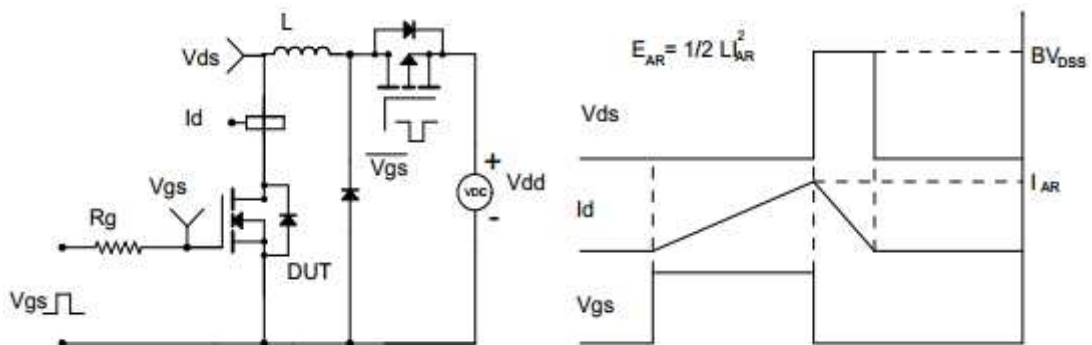
Transfer Characteristics

On Resistance Vs Gate Source Voltage

Capacitance



Gate Charge Waveform

Source-Drain Diode Forward Voltage

Maximum Safe Operating Area

Note : The above characteristics curves are presented for reference only and not guaranteed by production test, unless otherwise noted.



■ Test Circuit & Waveform
Gate Charge Test Circuit & Waveform

Resistive Switching Test Circuit & Waveform

Unclamped Inductive Switching (UIS) Test Circuit & Waveform

■ TO-252 Package Dimensions

Unit: mm

Symbol	Min	Nom	Max	Symbol	Min	Nom	Max
A	2.10		2.50	E	5.80		6.30
B	0.80		1.25	e1	2.25	2.30	2.35
b	0.50		0.85	e2	4.45		4.75
b1	0.50		0.90	L1	9.50		10.20
b2	0.45		0.60	L2	0.90		1.45
C	0.45		0.60	L3	0.60		1.10
D	6.35		6.75	K	-0.1		0.10
D1	5.10		5.50				

