

**MOSFETs Silicon 430V N-Channel MOS**
**■ Applications**

- Power factor correction (PFC)
- Switched mode power supplies(SMPS)
- Uninterruptible Power Supply (UPS)

**■ Features**

- Low  $R_{DS(ON)}$
- Ultra Low Gate Charge
- RoHS Compliant
- 100% UIS and RG Tested

**■ Product Summary**

$V_{DS}$	430	V
$I_D$	11	A
$R_{DS(ON)}, Typ @ 10V$	0.47	$\Omega$
$Q_g$	20	nC

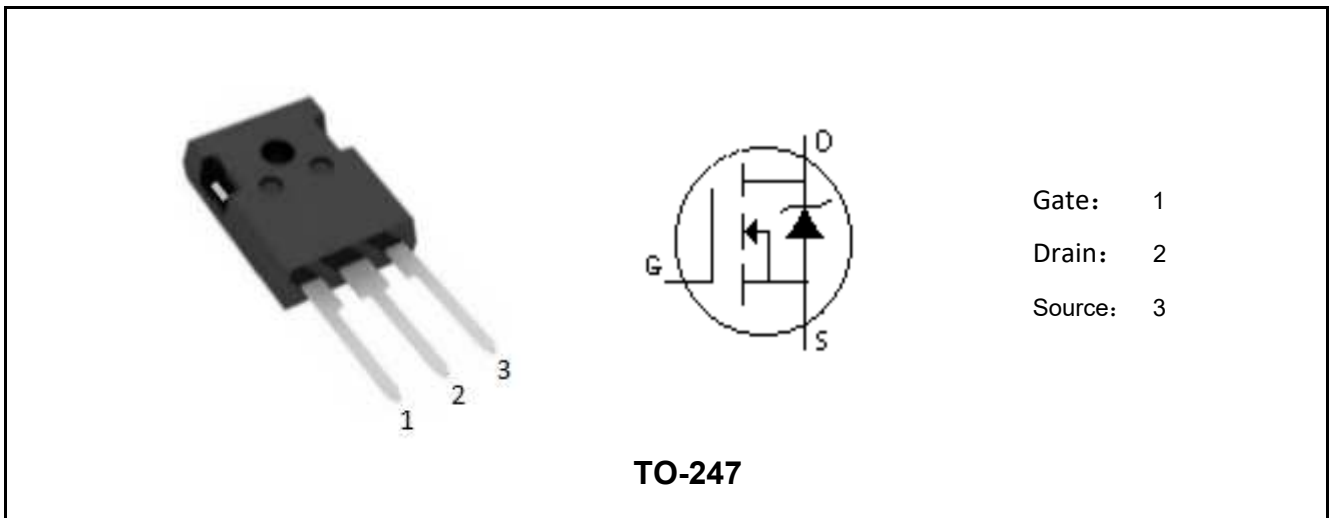

Marking	Package	Packaging	Min. package quantity
MSIRF11N45	TO-247	Tube	450



**■ Absolute Maximum Ratings (Tc=25°C unless otherwise noted)**

Parameter	Symbol	Ratings	Unit
Drain-Source Voltage	$V_{DS}$	430	V
Gate-Source Voltage	$V_{GS}$	±30	V
Continuous Drain Current Tc=25°C (Note 1)	$I_D$	11	A
Continuous Drain Current Tc=100°C (Note 1)		6.8	
Drain Current-Pulsed (Note 1)	$I_{DM}$	44	A
Total Dissipation	$P_D$	96	W
Junction Temperature	$T_j$	150	°C
Storage Temperature	$T_{stg}$	-55-150	°C
Single Pulse Avalanche Energy (Note 2)	$E_{AS}$	450	mJ

Note: Using continuously under heavy loads (e.g. the application of high temperature/current/voltage and the significant change in temperature, etc.) may cause this product to decrease in the reliability significantly even if the operating conditions (i.e. operating temperature/current/voltage, etc.) are within the absolute maximum ratings.

**■ Thermal Characteristics**

Parameter	Symbol	Max	Unit
Maximum Junction-to-Case	$R_{\theta JC}$	1.3	°C/W
Maximum Junction-to-Ambient	$R_{\theta JA}$	60	°C/W

Note 1: Ensure that the channel temperature does not exceed 150°C.

Note 2:  $V_{DD}=50V$ ,  $T_{ch}=25^\circ C$ (initial),  $I_{AS}=11A$ ,  $R_g=25\Omega$ .

Note 3: The value of  $R_{\theta JA}$  is measured with the device mounted on 1in2 FR-4 board with 2oz. Copper, in a still air environment with  $T_A=25^\circ C$ . The value in any given application depends on the user's specific board design.

Note: This transistor is sensitive to electrostatic discharge and should be handled with care.





### ■ Electrical Characteristics (Tc=25°C unless otherwise noted)

Parameter	Symbol	Test Condition	Min	Typ	Max	Unit
<b>Static Parameters</b>						
Drain-Source Breakdown Voltage	$BV_{DSS}$	$V_{GS}=0V, I_D=250\mu A$	430	-	-	V
Drain-Source Leakage Current	$I_{DSS}$	$V_{DS}=430V, V_{GS}=0V$	-	-	1	$\mu A$
Gate-Body Leakage Current	$I_{GSS}$	$V_{GS}=\pm 30V, V_{DS}=0V$	-	-	$\pm 100$	nA
Gate Threshold Voltage	$V_{GS(TH)}$	$V_{GS}=V_{DS}, I_D=250\mu A$	2	3	4	V
Drain-Source On Resistance	$R_{DS(ON)}$	$V_{GS}=10V, I_D=5.5A$	-	0.47	0.5	$\Omega$
<b>Dynamic Characteristics</b>						
Input Capacitance	$C_{iss}$	$V_{DS}=25V, V_{GS}=0V,$ $f=1.0MHz$	-	1120	-	pF
Output Capacitance	$C_{oss}$		-	118	-	pF
Reverse Transfer Capacitance	$C_{rss}$		-	10	-	pF
Gate Resistance	$R_g$	$V_{DS}=0V, V_{GS}=0V,$ $f=1.0MHz$	-	2	-	$\Omega$
<b>Switching Parameters</b>						
Turn-On Delay Time	$t_{d(on)}$	$V_{DS}=250V, I_D=11A,$ $V_{GS}=10V, R_G=25\Omega$	-	32	-	ns
Turn-On Rise Time	$t_r$		-	28	-	ns
Turn-Off Delay Time	$t_{d(off)}$		-	90	-	ns
Turn-Off Rise Time	$t_f$		-	50	-	ns
Total Gate Charge	$Q_g$	$V_{DS}=320V, I_D=11A,$ $V_{GS}=10V$	-	20	-	nC
Gate-Source Charge	$Q_{gs}$		-	6.5	-	nC
Gate-Drain Charge	$Q_{gd}$		-	4.5	-	nC
<b>Source-Drain Characteristics</b>						
Max. Diode Forward Current	$I_S$		-	-	11	A
Max. Pulsed Forward Current	$I_{SM}$		-	-	44	A
Diode Forward Voltage	$V_{SD}$	$V_{GS}=0V, I_S=11A$	-	0.86	1.5	V
Reverse Recovery Time	$t_{rr}$	$V_R=320V, I_F=11A,$ $di/dt=100A/\mu s$	-	320	-	ns
Reverse Recovery Charge	$Q_{rr}$		-	3.2	-	$\mu C$





### Characteristics Curves

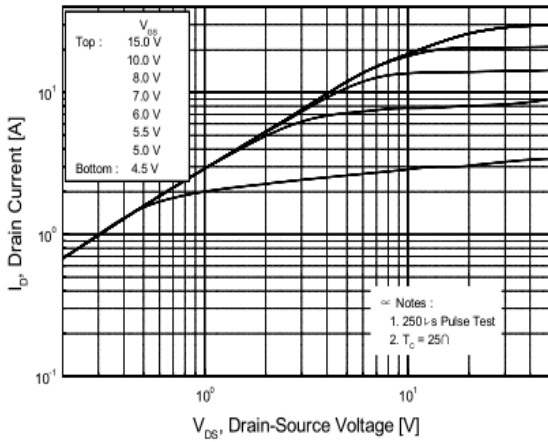

Output Characteristics

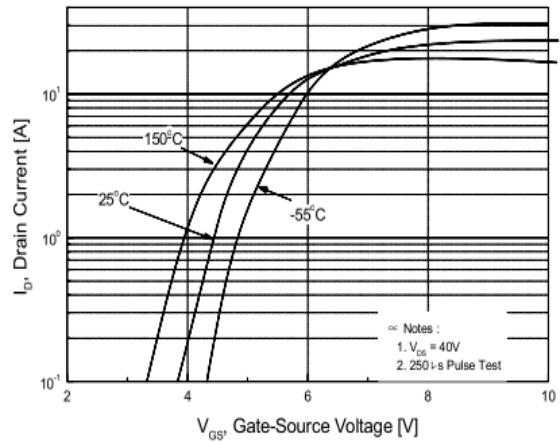

Transfer Characteristics

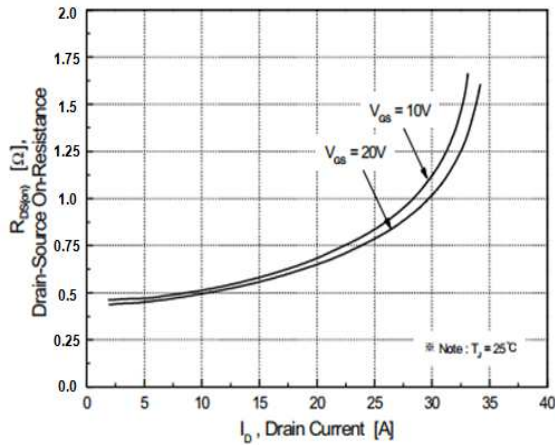

On Resistance Vs Drain Current

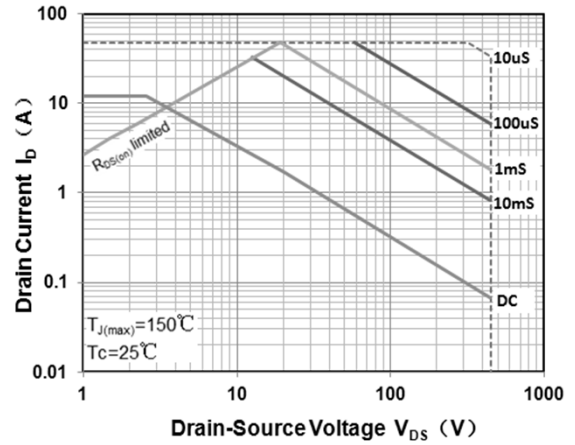

Safe Operating Area

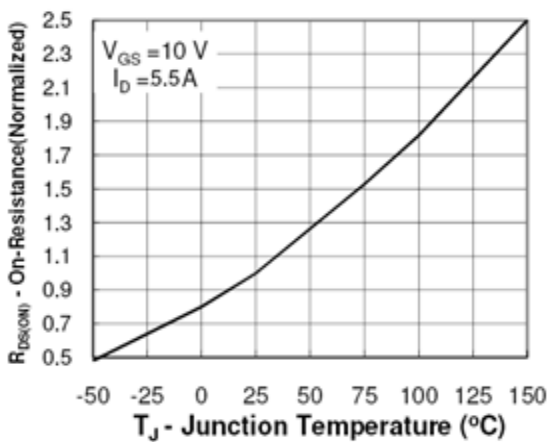

Rdson-Junction Temperature

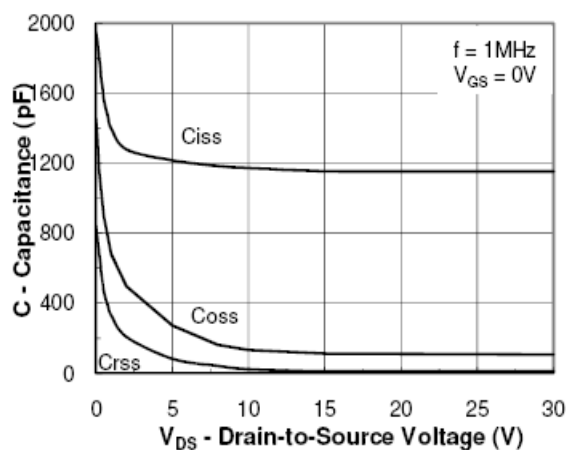

Capacitance



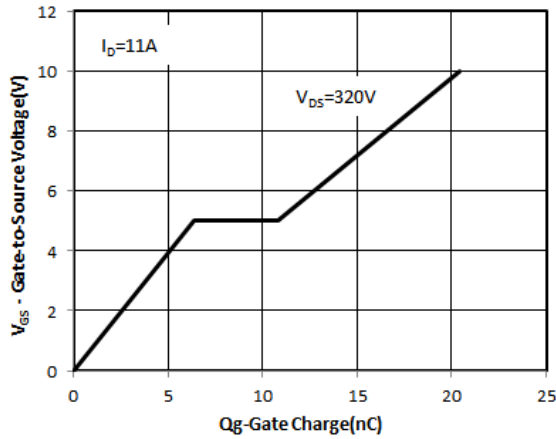

Gate Charge Waveform

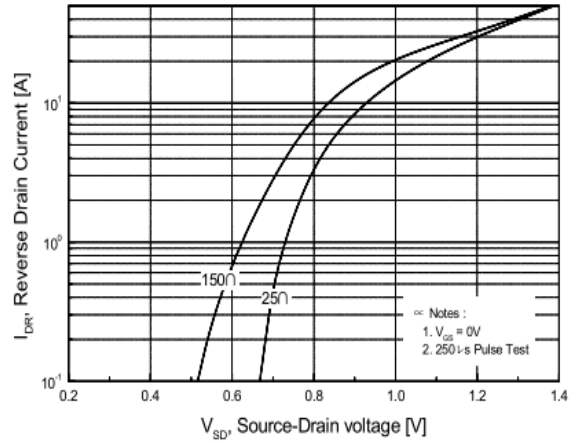

Source-Drain Diode Forward Voltage

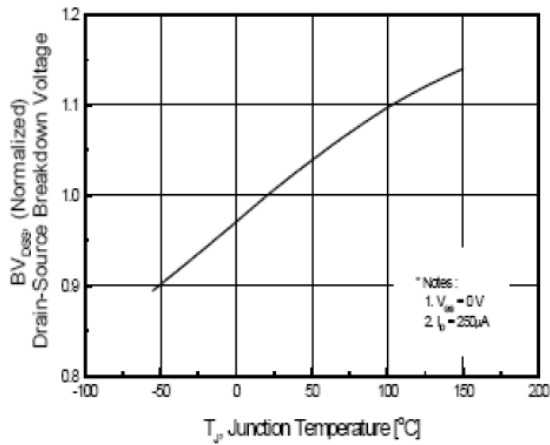

Breakdown Voltage Vs Junction Temperature

Note : The above characteristics curves are presented for reference only and not guaranteed by production test, unless otherwise noted.





■ Test Circuit & Waveform

Gate Charge Test Circuit & Waveform

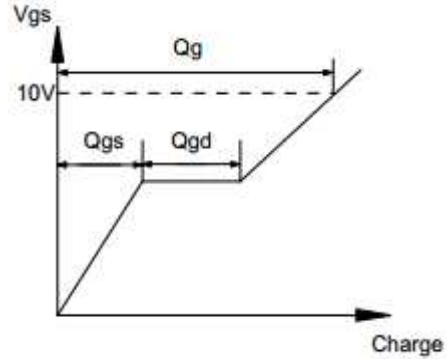
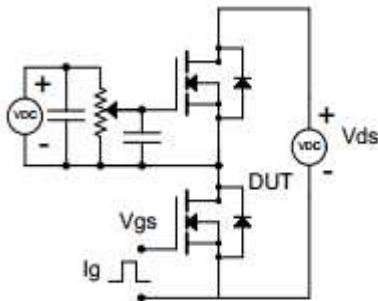

Resistive Switching Test Circuit & Waveform

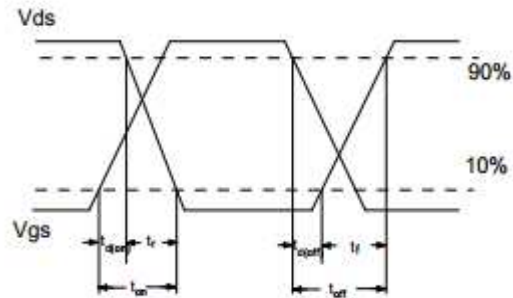
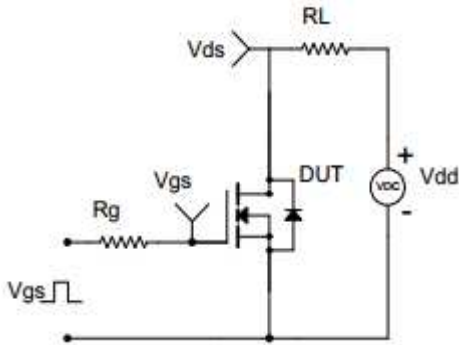

Unclamped Inductive Switching (UIS) Test Circuit & Waveform

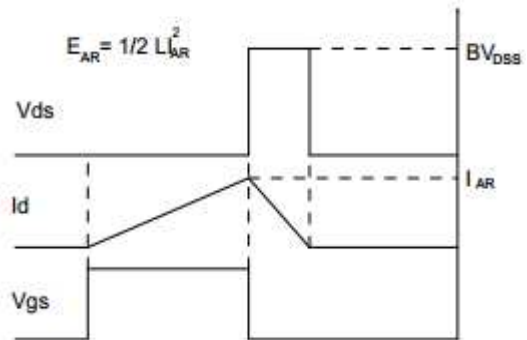
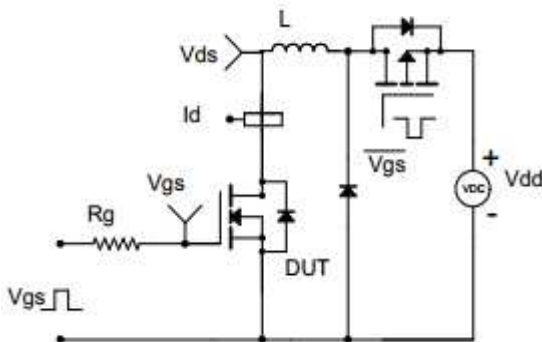



■ TO-247 Package Dimensions

Unit: mm

Symbol	Min	Nom	Max	Symbol	Min	Nom	Max
A	4.60		5.15	A1	1.30		1.60
b	2.86		3.26	b1	1.86		2.26
b2		1.20		C		0.50	
D	19.00		21.00	E	15.45		15.75
E1	12.00		13.06	e		5.45	
L	14.00		14.60	L1	5.20		5.88
L2	24.00		24.40	L3	10.00		10.60
ΦP		3.50		Q	2.30		2.70

